

2003 G
PC



"the motorhome people"[®]

Traveler[™]

OWNERS MANUAL

MOTOR HOMES BY

GEORGIE BOY MANUFACTURING, LLC

69950 M-62 • Edwardsburg, Michigan 49112 • Phone (616) 663-3415

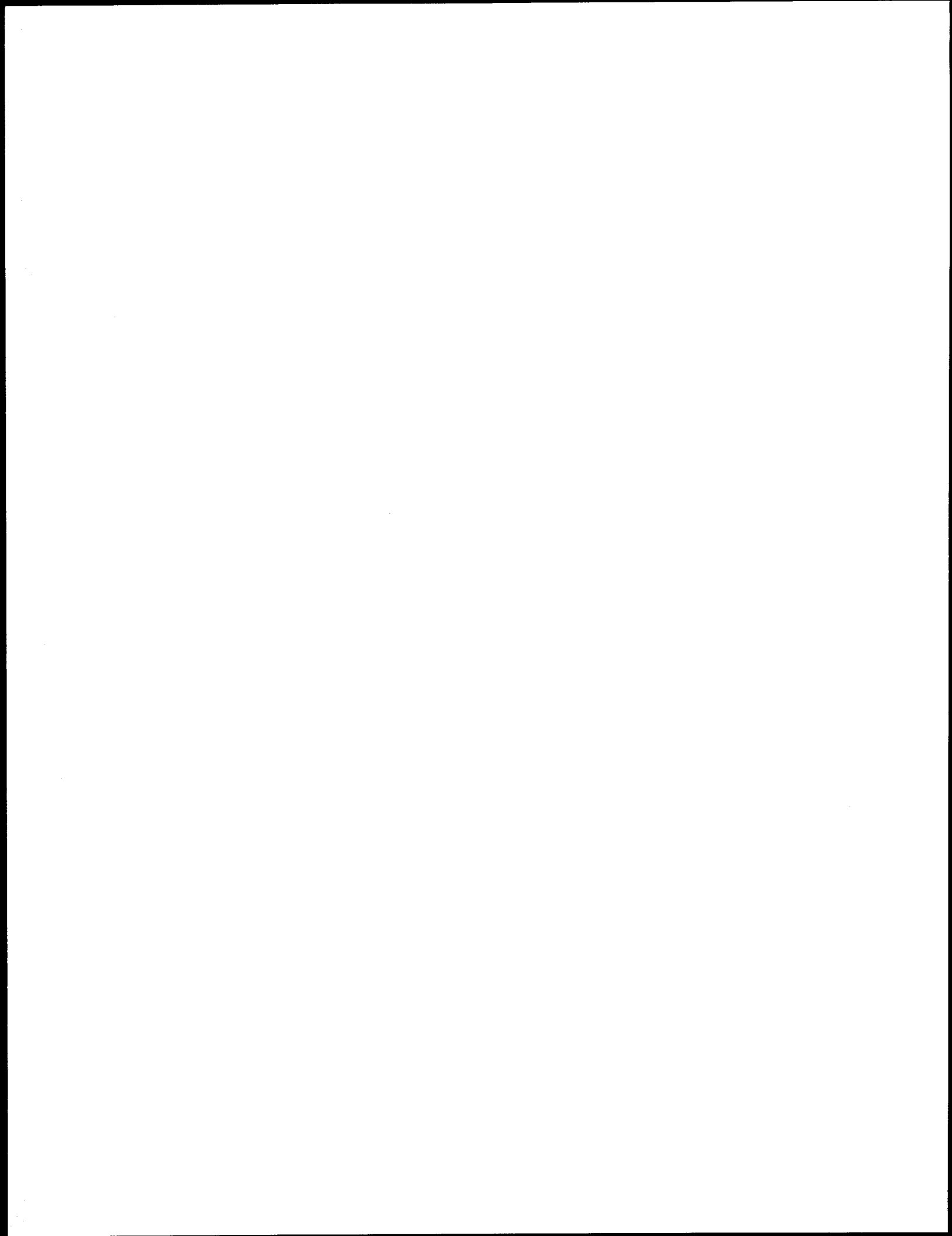

Welcome to Georgie Boy's® growing family of satisfied RV owners. Hours of relaxation, adventure and enjoyment await you in your new Georgie Boy unit. Thousands of Georgie Boy Mfg. owners have been enjoying their purchase for many years.

This Owner's Manual has been prepared to help you and your family enjoy your new Georgie Boy Mfg. by providing basic instructions for the operation and maintenance of the appliances, accessories and RV systems. Please read it carefully and follow the instructions. Also read and follow the instructions contained in the chassis, appliance and accessory manufacturers' instruction booklets provided with your RV.

If you have any questions regarding operation, maintenance or service, please contact Georgie Boy Mfg. or your Georgie Boy dealer so we can assist you. Your complete satisfaction is of the utmost importance to your dealer and to Georgie Boy.

Operation and maintenance instructions regarding appliances in this manual were obtained from the manufacturer's booklets and are used with the permission of those various manufacturers. Georgie Boy Mfg. reserves the right to present edited portions of these materials.

Georgie Boy offers a wide variety of recreational vehicle models and choices of standard and optional equipment; therefore, certain descriptions in this manual may not apply to your unit. Ask your authorized dealer, or see the current brochure for information on the availability of standard or optional equipment.

Thank you for selecting our product. The entire Georgie Boy family wishes you many safe and enjoyable journeys in your new RV.

NOTE: Georgie Boy Manufacturing, LLC works year round to improve its product. As a result, all specifications and equipment are subject to change without notice or obligation to the customer. All information contained in this Owners Manual is believed to be accurate at the time of publication, however; during the model year, it may be necessary to make revisions and Georgie Boy reserves the right to make all such changes without notice.

Table of Contents

WELCOME	1	BASIC UTILITY SYSTEMS	19
Table of Contents	3	Monitor Panels	19
Warranty	4-5	110-Volt System	19
Safety Regulations	6	Ground Fault Interrupter	19
Introduction/Taking Delivery	7	Shoreline Connection	20
Obtaining Service	8	Power Converter	20
Important Documents	8	Auxiliary Generator	20
LOADING/WEIGHING	8	12-Volt System	21
Weight Determinations	9	In-Line Fuses	21
Vehicle Weighing	10	Power Distribution Chart	21
Hitch types	10	FRESH WATER SYSTEM	22
CAMPING & LEVELING VEHICLE	11	Sanitizing the Water Tank	22
DRIVING YOUR MOTORHOME	13	Water Pump	23
Instrument Panels	13	DRAINAGE/SEWER SYSTEM	23
Seat Belts	14	Emptying the Holding Tanks	23
Clearance	14	LP GAS SYSTEM	24
Mirrors	14	Climate Differences	25
OPERATING YOUR VEHICLE	14	Regulator Pressure	26
Pulling into Traffic	14	LP Leak Detector	26
Passing	14	LP Gas Regulator Freeze-Ups	26
Braking/Stopping Distance	14	Filling LP Gas Tanks	26
Parking on a Grade	15	LP Gas Line Check	27
Downgrades	15	APPLIANCES/ACCESSORIES	27
Upgrades	15	Range, Range Hood, Oven	28
Overheating	15	Microwave Oven	28
Swaying or Fishtailing	15	Gas Water Heater	28
Turning Corners	15	Furnace/Roof Air Conditioner	29
Backing	15	Refrigerator	30
Freeing a Stuck Vehicle	15	Monitor Panel	31
Towing	15	Electric Step	31
SLIDE OUT SYSTEMS	16	FIRE/SAFETY	33
Liftco System	16	VEHICLE MAINTENANCE	32
RBW and Power Gear Systems	17	Storage	32
LIVING AREA	16	Winterization	32
Air Quality	16	Interior/Exterior Care	33
Condensation	17	Pre-Travel Checks	37
Driver and Passenger Seats	18	Troubleshooting	39
Smoke Detector	18	Travel Record	43
Fire Extinguisher	18	Maintenance Record	44
Carbon Monoxide Detector	18	Maintenance Schedule	45
Windshield Privacy Drapes	19	Appliance ID Form	46
		Reporting Safety Defects	48



EXTENDED STRUCTURAL LIMITED WARRANTY

SUMMARY OF WARRANTY COVERAGE:

This Extended Structural Limited Warranty provided by Georgie Boy Manufacturing, LLC, (hereinafter "Warrantor"), covers the structural portion of new recreational vehicles sold by an authorized dealer for two (2) years from either the original retail purchase date, the date the vehicle was first put into use or the first 25,000 miles of total use, whichever occurs first. So long as you notify Warrantor or one of its authorized servicing dealers of the defect in original materials, workmanship or design within the warranty coverage period, Warrantor will make repairs to the structural portion of the recreational vehicle as described below which may become necessary due to defects in original materials, workmanship or design. Warrantor will repair the structural portion of the recreational vehicle at its sole cost and expense. The warranty registration form must be returned to Warrantor promptly upon purchase to assure proper repair and to activate your warranty. Because of design changes, Warrantor may substitute parts or components of substantially equal quality. This extended Structural Limited Warranty applies only to the original retail owner and is not transferable.

The Structural portion of the recreational vehicle means the interior and exterior sidewalls, floor structure and ceiling assembly. The Structural portion also includes the truss frame of any motorhome.

Defects and damage to interior and exterior surfaces and other appearance items may occur at the factory during manufacture. Normally, any factory defect or damage is detected and corrected at the factory during the inspection process performed by the Warrantor. If you discover any such defect or damage when you take delivery of the vehicle, please notify your dealer or Warrantor.

EXCLUSION:

The Extended Structural Limited Warranty does not cover the automotive chassis, normal wear and usage, such as fading or discoloration, defacing, scratching, dents and chips on any surface of the recreational vehicle, not caused by Warrantor, routine maintenance, flaking, peeling or other defects in the exterior or finished caused by the environment including airborne pollutants, salt, tree sap and hail.

EVENTS DISCHARGING WARRANTOR FROM OBLIGATION UNDER WARRANTY:

Misuse or neglect, including accident, unauthorized alteration, failure to provide reasonable and necessary maintenance, recreational vehicle not registered or used in the United States or Canada. Also, use of the recreational vehicle for rental or commercial purposes or any other use other than personal and recreational use, shall discharge Warrantor from any obligation under this Extended Structural Limited Warranty.

LIMITATIONS OF IMPLIED WARRANTIES:

IMPLIED WARRANTIES, INCLUDING THE IMPLIED WARRANTY OF MERCHANTABILITY AND IMPLIED WARRANTY OF FITNESS FOR A PARTICULAR PURPOSE, AND LIMITED IN DURATION TO THE TERM OF THIS WARRANTY. There is no warranty made by any dealer or other person beyond those expressly set forth in the Warranty. Some states do not allow limitations on how long an implied warranty lasts, so the above limitation may not apply to you.

DISCLAIMER OF CONSEQUENTIAL AND INCIDENTAL DAMAGES:

THE ORIGINAL PURCHASER OF THE VEHICLE AND ANY PERSON WHO IS AN INTENDED OR UNINTENDED USER OR BENEFICIARY OF THE VEHICLE, SHALL NOT BE ENTITLED TO RECOVER FROM WARRANTOR ANY CONSEQUENTIAL OR INCIDENTAL DAMAGES RESULTING FROM ANY DEFECT IN THE RECREATIONAL VEHICLE. Some states do not allow the exclusion or limitation of consequential or incidental damages so the above exclusions may not apply to you.

OBTAINING WARRANTY SERVICE:

For warranty service, simply contact Warrantor's authorized dealer or service center for an appointment or consultation; then take the vehicle (at your expense) to the servicing facility.

LEGAL REMEDIES:

ANY ACTION TO ENFORCE THIS WARRANTY SHALL NOT BE COMMENCED MORE THAN ONE (1) YEAR AFTER THE EXPIRATION OF THIS WARRANTY.

This warranty gives you specific legal rights and you may also have other rights that vary from state to state.

Most of all, we want you to be very satisfied with your new Georgie Boy product. For help or information, please contact Warrantor at 1-800-521-8733.



NEW RECREATIONAL VEHICLE LIMITED WARRANTY

SUMMARY OF WARRANTY COVERAGE:

This warranty provided by Georgie Boy Manufacturing, LLC (hereinafter "Warrantor") covers new vehicles sold by one of its authorized dealers for one year from either the original purchase date or the date the vehicle was first put into use, or the first 15,000 miles of total use; whichever occurs first. So long as you notify Warrantor or one of its' authorized servicing dealers of the defect in original materials or workmanship within the warranty coverage period, Warrantor will make any repairs to both the recreational and the automotive portions of the vehicle as described below, which may become necessary due to defects in original materials or workmanship. Warrantor will repair or replace any defective part at its' sole cost and expense. The Warranty Registration form must be returned to Warrantor promptly upon purchase to assure proper part replacement or repair and to activate your Warranty. Because of design changes, Warrantor may substitute parts or components of substantially equal quality.

Defects and damage to interior and exterior surfaces, trim, upholstery and other appearance items may occur at the factory during manufacture. Normally, any factory defect or damage is detected and corrected at the factory during the inspection process performed by the Warrantor. If you discover any such defect or damage when you take delivery of the vehicle, please notify your dealer or Warrantor.

The recreational portion of the vehicle means all portions of the vehicle used or primarily maintained as a mobile dwelling, and excludes any components typically found in an automobile. The recreational portion of a vehicle, which is also commonly referred to as "living facilities", include but are not limited to the plumbing system and fixtures, ducting and appliances for the roof air conditioners(s) and furnace, electrical systems unrelated to the propulsion of the vehicle, the entrance door other than the driver and/or passenger door, exterior compartments and windows other than the windshield and the driver and passenger window.

The automotive portion to the vehicle means those portions of the vehicle typically found in an automobile, which were installed by Warrantor. For example, in Class "A" Motorhomes, the automotive portion of the vehicle may include the driver and passenger doors, windshield and driver and passenger window, windshield wipers, dash air conditioner and heater, dash gauges and controls, exterior automotive lights and mirrors. However, in those cases involving Class "C" Motorhomes, the automotive portion of the vehicle would not include the driver and passenger door, windshield and driver and passenger window, windshield wipers, dash air conditioner and heater, dash gauges and controls and exterior lights.

EXCLUSIONS:

This limited warranty applies to materials and components originally manufactured or installed by Warrantor. It does not cover items which are added or changed after the vehicle leaves Warrantor's possession; normal wear and usage, such as fading or discoloration of fabrics, or the affects of condensation inside the vehicle; defacing, scratching, dents and chips on any surface or fabric of the vehicle not caused by Warrantor; routine maintenance, the automotive chassis including the engine, drivetrain, steering and handling, overloading, braking, wheel balance, muffler, tires, tubes, batteries and gauges; flaking, peeling or other defects in the exterior or finish caused by the environment including airborne pollutants, salt, tree sap and hail.

EVENTS DISCHARGING WARRANTOR FROM OBLIGATION UNDER WARRANTY:

Misuse or neglect, including accident, unauthorized alteration, failure to provide reasonable and necessary maintenance, including used of the vehicle for rental or commercial purposes or any other use other than personal and recreational use, shall discharge Warrantor from any obligation under this limited warranty.

LIMITATION OF IMPLIED WARRANTIES:

IMPLIED WARRANTIES, INCLUDING THE IMPLIED WARRANTY OF MERCHANTABILITY AND IMPLIED WARRANTY OF FITNESS FOR A PARTICULAR PURPOSE, ARE LIMITED IN DURATION TO THE TERM OF THIS LIMITED WARRANTY. There is no warranty of any nature made by Warrantor beyond that contained in this Warranty. No person has authority to enlarge, amend or modify this warranty. The dealer is not the Warrantor's agent but is an independent entity. Warrantor is not responsible for any undertaking, representation or warranty made by any dealer or person beyond those expressly set forth in this warranty. Some states do not allow limitations on how long an implied warranty lasts, so the above limitation may not apply to you.

DISCLAIMER OF CONSEQUENTIAL AND INCIDENTAL DAMAGES:

THE ORIGINAL PURCHASER OF THE VEHICLE AND ANY PERSON WHOM THE VEHICLE IS TRANSFERRED, AND ANY PERSON WHO IS AN INTENDED OR UNINTENDED USER OR BENEFICIARY OF THE VEHICLE, SHALL NOT BE ENTITLED TO RECOVER FROM WARRANTOR ANY CONSEQUENTIAL OR INCIDENTAL DAMAGES RESULTING FROM ANY DEFECT IN THE VEHICLE. Some states do not allow the exclusion or limitation of consequential or incidental damages, so the above exclusions may not apply to you.

OBTAINING WARRANTY SERVICE:

For Warranty service simply contact one of Warrantor's authorized service centers for an appointment, then deliver your vehicle (at your expense) to the service center.

LEGAL REMEDIES:

ANY ACTION TO ENFORCE THIS WARRANTY SHALL NOT BE COMMENCED MORE THAN ONE (1) YEAR AFTER THE EXPIRATION OF THIS WARRANTY.

This warranty gives you specific legal rights, and you may also have other rights which vary from state to state. Most of all, we want you to be very satisfied with your new Georgie Boy product. For help or information, please contact Warrantor at 1-800-521-8733.

IMPORTANT SAFETY REGULATIONS

... please read carefully.

LP GAS SYSTEMS AND APPLIANCES

Georgie Boy Manufacturing LLC is required to furnish the following consumer information as provided by the National Fire Prevention Association and the American National Standards Institute. The information and warnings found here may also be found in other sections of this Owner's Manual. Please see sections titled "Liquid Petroleum Gas System" and "Appliances" for other safety and operating information.

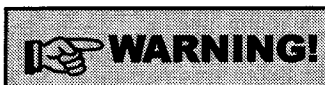

LP gas containers shall not be placed or stored inside the vehicle. LP gas containers are equipped with safety devices which relieve excessive pressure by discharging gas to the atmosphere.

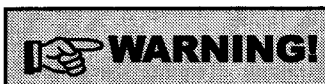

It is not safe to use cooking appliances for comfort heating. Cooking appliances need fresh air for safe operation. Before operation

1. Open an overhead vent or turn on exhaust fan
2. Open a window.

A warning label has been located in the cooking area to remind you to provide an adequate supply of fresh air for combustion. Unlike homes, the amount of oxygen supply is limited due to the size of the recreational vehicle, and proper ventilation when using the cooking appliance(s) will avoid dangers of asphyxiation. It is especially important that cooking appliances not be used for comfort heating as the danger of asphyxiation is greater when the appliance is used for long periods of time.

Portable fuel-burning equipment, including wood

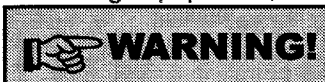

and charcoal grills and stoves, shall not be used inside this recreational vehicle. The use of this equipment inside the recreational vehicle may cause fires or asphyxiation.



Do not bring or store LP gas containers, gasoline, or other flammable liquids inside the vehicle because a fire or explosion may result.

A warning label has been located near the LP gas container. This label reads: DO NOT FILL CONTAINER(S) TO MORE THAN 80 PERCENT OF CAPACITY.

Overfilling the LP gas container can result in uncontrolled gas flow which can cause fire or explosion. A properly filled container will contain approximately 80 percent of its volume as liquid LP gas.

The following label has been placed in the vehicle near the range area:

IF YOU SMELL GAS:

1. Extinguish any open flames, pilot lights and all smoking materials.
2. Do not touch electrical switches.
3. Shut off the gas supply at the tank valve(s) or gas supply connection.
4. Open doors and other ventilating openings.
5. Leave the area until odor clears.
6. Have the gas system checked and leakage source corrected before using again.

LP gas regulators must always be installed with the diaphragm vent facing downward. Regulators that are not in compartments have been equipped with a protective cover. Make sure that regulator vent faces downward and the cover is kept in place to minimize vent blockage which could result in excessive gas pressure causing fire or explosion.

INTRODUCTION

Congratulations on the purchase of your new Georgie Boy® recreational vehicle. We sincerely thank you for choosing our product. To help you enjoy it, you'll find in this Owner's manual many useful tips for the basic operation and maintenance of your Georgie Boy vehicle's systems and appliances.

TRY A SHORT TRIP FIRST. The experience you will gain from this will help make your future RV'ing more enjoyable. To complement the standard and optional equipment you've chosen for your vehicle, there are many other accessories available. You may wish to use your vehicle several times before you invest in these accessories. What may be a necessity for one RVer could prove to be of no value to you. Remember, your dealer is always ready to help and advise you.

If you are a first-timer, we want you to learn to operate your vehicle correctly, to be able to use its components, appliances and any optional equipment in the most efficient manner.

If you're a veteran RV'er, you know that things change and a quick review of this manual will bring you up to date on what's new. So read on. Happy camping!

***Note:** Because of individual tastes and the different floorplans offered, your vehicle may not have all of the components illustrated or described in this manual. Ask your dealer for details concerning the specifics of your vehicle.*

TAKING DELIVERY

Your recreational vehicle has been inspected by factory personnel throughout the manufacturing process. Our final factory check by quality control inspectors is not the last one. Your dealer performs additional pre-delivery inspections and systems checks, and helps you understand the Warranty and complete any necessary forms.

Dealer Responsibilities Include:

1. Orienting the customer to the recreational

vehicle, its systems and components, and their operation.

2. Insuring the customer receives a complete Owner's Packet with warranty cards and registrations for the recreational vehicle and for separately warranted products, including operating and maintenance instructions.
3. Reviewing Limited Warranty provisions with the customer, stressing the coverage, assisting the customer in completing these forms if he wishes, and requesting that the customer read all warranty information as soon as possible explaining any provisions not clearly understood.
4. Instructing the customer how to get local service and out-of-town service on the recreational vehicle and its separately warranted components, either in or out of warranty.

GENERAL DRIVING CHECKS

For your safety, make certain that the following items have been checked and rechecked before you take your RV on the road. Be sure to read APPENDIX A: PRE-TRAVEL CHECK for additional driving checks.

Hydraulic Levelers—Must be raised as far as possible.

Lights—The following lights should be tested: brake lights, warning lights, flashers, clearance lights, taillights, headlights and instrument panel lights.

Side Mirrors—Adjust all mirrors so the driver can see the right and left side of the unit.

TV Antenna—Lowered.

Customer Responsibilities

As a new recreational vehicle owner, you have the responsibility for regular and proper maintenance. This will help you avoid conditions arising from neglect that are not covered by your Georgie Boy Manufacturing LLC Vehicle Limited Warranty. Maintenance services should be performed in accordance with this Owner's Manual, the chassis Owner's Manual, and any other applicable manuals. As the owner, it is your responsibility and obligation to return the recreational vehicle to an authorized dealer for repairs and service

(SEE LIMITED WARRANTY). Since the Authorized Dealer from whom you purchased your new recreational vehicle is responsible for its proper servicing before delivery, and has an interest in your continued satisfaction, we recommend that inspection, warranty and maintenance services be performed by them.

OBTAINING SERVICE

Give Thought to the Appointment Time

Know when to take your vehicle in for service. Monday and Friday are the busiest days at most dealerships. Therefore, try to make a mid-week appointment whenever possible.

Prepare for the Appointment . . .

If you're having warranty work done, be sure to have your warranty card with you. All work to be performed may not be covered by the warranty; discuss additional charges with the service manager. Keep a maintenance log of your vehicles' service history. This can often provide a clue to the current problem.

Prepare a List . . .

Prepare a written list of issues or specific work you require to be done. Advise the Service Manager if work has been performed that is not listed on your Maintenance Log. It is important to keep the log accurate and up to date.

Be Reasonable with Your Requests . . .

Appointments are made according to the type of repair scheduled, and the amount of time needed to complete the repair. If you add items after the appointment has been set, discuss the situation with the service manager and list your items in order of priority. Expect to make a second appointment for work not completed or for parts that may need to be ordered.

No offense . . .

Insurance requirements forbid the admission of customers to a service repair area.

Inspect the Work Properly . . .

Inspect the completed repairs when you pick up your vehicle and notify the Service Manager of any dissatisfaction.

IMPORTANT DOCUMENTS

Always carry your vehicle registration, insurance policy card(s) and owner warranty registration. If you lend your vehicle, it is best to give the borrower a notarized letter authorizing him to be in possession of the vehicle.

Licenses

Vehicle licensing laws vary from state-to-state. Check with your state license bureau or the nearest licensing branch office for the requirements of your state.

Insurance

Consult your insurance agent about personal liability, property damage, collision and theft of contents insurance for your new recreational vehicle. Always carry your insurance policy and/or card with you when you travel. Obtain current road maps and tourist information for each state you'll visit or drive through. You also may want to purchase a tourist guide book

LOADING / WEIGHING

A correctly loaded vehicle is necessary for safe operation. Distribute your cargo evenly from side-to-side and from front-to-back. Heavier items should be stored as centrally as possible, on or near the floor. They should be secured so that they cannot slide during a sudden stop and cause damage. (loose cargo can alter the balance you had when you started.). Lighter items can be stored in overhead cabinets or other areas.

Remember to leave space and weight allowance for souvenirs and other items you may purchase during your travels. A properly loaded vehicle can help conserve fuel and can prevent excessive wear on your vehicle's automotive system.

Weight Information Sheet

The last process your unit undergoes before shipping it to the dealer is weighing it on our certified scales. The unit is weighed with all selected options installed. This information is then provided to you in the form of a Unit Weight Information Sheet. The sheet is typically located inside an overhead galley cabinet door. (See the sample on the following page.)

MOTORIZED - UNIT WEIGHT INFORMATION SHEET

Georgie Boy® motorhomes are designed to allow for a wide variety of uses from extended trips with two people to short trips with multiple people. Accordingly, each unit allows ample room for sleeping, seating, fluids and cargo. While the customer is the beneficiary of this design, the customer also bears the responsibility to select the proper combination of passengers, cargo load and towed vehicle without exceeding the chassis weight capabilities.

Seat belts are required to be worn in most states, and should always be used for passenger safety. Seat belts have been provided at most seating locations to allow convenience in selecting which seat to occupy. However, it is not intended that all seating positions equipped with seat belts may be occupied while the vehicle is in motion, without regard to other weight factors.

DO NOT EXCEED THE CARGO CARRYING CAPACITY OF THIS VEHICLE

PRODUCT

**SER #
VIN #**

FRONT GAWR	LBS.	REAR GAWR:	LBS.	CENTER GAWR	LBS.
LEFT FRONT	LBS.	*ACTUAL WEIGHT AS MANUFACTURED*		RIGHT FRONT	LBS.
LEFT REAR	LBS./TAG	LBS.	RIGHT REAR	LBS./TAG	LBS.

- LBS. GVWR** (GROSS VEHICLE WEIGHT RATING) is the maximum permissible weight of this fully loaded motorhome. The GVWR is equal to or greater than the sum of the Unloaded Vehicle Weight plus the Net Carrying Capacity.
- LBS. UVW** (UNLOADED VEHICLE WEIGHT) is the weight of this motorhome as manufactured at the factory with full fuel, engine oil, and coolants. The UVW does not include cargo, fresh water, LP gas, occupants, or dealer installed accessories.
- LBS. NCC** (NET CARRYING CAPACITY) is the maximum weight of all occupants including the driver, personal belongings, food, fresh water, LP gas, tools, tongue weight of towed vehicle, dealer installed accessories, etc., that can be carried by this motorhome. (NCC is equal to or less than GVWR minus UVW).
- LBS. GCWR** (GROSS COMBINATION WEIGHT RATING) is the value specified by the motorhome manufacturer as the maximum allowable loaded weight of this motorhome with its towed trailer or towed vehicle. Actual GCWR of this vehicle may be limited by the sum of the GVWR and the installed hitch rated capacity. See hitch rating label for detail.
- LBS. GAWR** (GROSS AXLE WEIGHT RATING) is the allowable weight including cargo, which can safely be supported by each axle.

NOTE:

- a. Dealer installed equipment and towed vehicle tongue weight will reduce NCC
 - b. Option weights in LBS. (Net Weight Added For Manufacturer Installed Options)
- All option weights are approximate and provided to assist the operator in the proper loading of this vehicle.

WARNING! CONSULT OWNER MANUAL(S) FOR SPECIFIC WEIGHING INSTRUCTIONS AND TOWING GUIDELINES INCLUDING AUXILIARY BRAKE REQUIREMENTS FOR ANY TOWED TRAILER OR TOWED VEHICLE

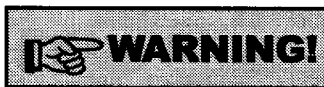

Exceeding the GVW and GAW ratings for your vehicle could result in serious damage to the suspension, frame or other components of your vehicle. Use of heavier suspension components (springs, shocks, axles) or heavier-ply tires does not increase the weight ratings printed on the vehicles' certification plate. The GAWR of each axle is determined by the axle system components with the lowest weight-carrying capacity. To avoid overloading your vehicle check the GVWR and GAWR.

WEIGHT DETERMINATIONS

It is extremely important that you weigh your vehicle, fully loaded with your travel equipment, before you leave on a trip. Check the Gross Axle Weight Rating (GAWR) and the Gross Vehicle Weight Rating (GVWR) found on the Federal Sticker and the unit weight information sheet affixed to each vehicle. The Federal Sticker or certificate lists the unit Serial Number and the front and rear GAWR and GVWR. It is located to the left of the driver's seat. We suggest that you record this sticker information in the space provided here to ensure that you always have the information close at hand.

GVWR _____ GAWR Front _____

GAWR Rear _____ with _____ tires

RIMS _____ at _____ PSI Cold _____

You can weigh your vehicle at a grain elevator, sand and gravel dealer, or government weighing station. There may be a small fee for weighing your vehicle; however, it is an investment in safe traveling and peace of mind. Check your Yellow Pages for the address and telephone number of the weighing facility nearest you.

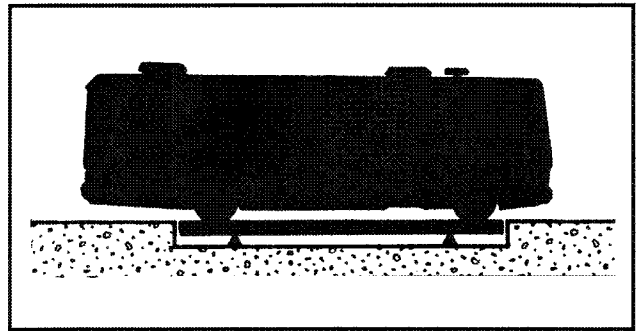

GROSS VEHICLE WEIGHT

STEP 3—Pull forward so that only the rear axle is on the scale. Compare the weight to the rear GAWR listed on the Federal Sticker.

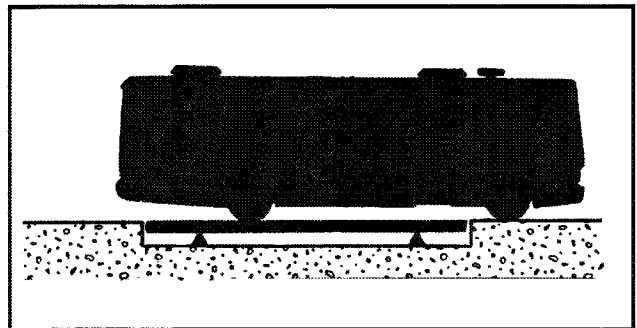

REAR GROSS AXLE WEIGHT

Note: If any of the weights exceed the listed rating, relocate the passengers and redistribute or remove a portion of the cargo until the weight is within the proper tolerance.

MFD. BY:	DATE			
MFC. VEH.:	DATE			
MFD. BY:	DATE			
GAWR LB	TIRES	PSI COLD SINGLE	PSI COLD DUAL	RIMS
FRONT				
INTER-				
MEDIATE				
REAR				
GVWR LB	MODEL NUMBER			
TYPE	VEHICLE ID NUMBER			
THIS VEHICLE CONFORMS TO ALL APPLICABLE FEDERAL MOTOR VEHICLE SAFETY STANDARDS IN EFFECT IN				

Federal Sticker

VEHICLE WEIGHING

STEP 1—Drive only the front wheels of the unit onto the scale. Compare the weight to the front GAWR listed on the Federal Sticker.

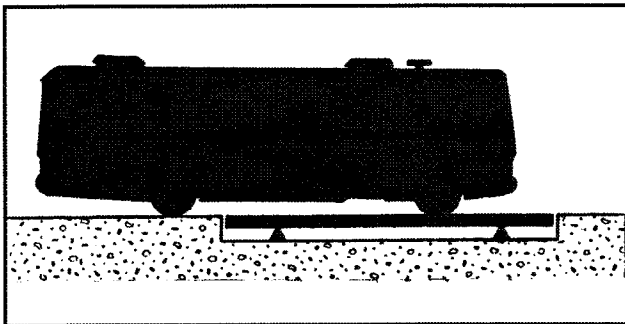

FRONT GROSS AXLE WEIGHT

STEP 2—Pull forward so that the front and rear axles are on the scale. Compare the weight to the GVWR listed on the Federal Sticker.

TOWING

If your vehicle is equipped with an optional hitch towing package, do not exceed the Gross Combined Weight Rating (GCWR) as stated in the chassis manufacturer's owner's manual, or the rated capacity of the installed hitch (whichever is less).

HITCH TYPES

STANDARD

Class	Type	Max. G.T.W.	Max T.W.
I	Weight Carrying	2000 lbs	200 lbs
II	Weight Carrying	3500 lbs	300 lbs
III	Weight Carrying	5000 lbs	500 lbs
IV	Weight Distributing	10000 lbs	1000 lbs
V	Weight Distributing	14000 lbs	1700 lbs

(G.T.W.=Gross Trailer Wt. T.W.=Tongue Wt.)

Note: As carrying capacities may vary by hitch manufacturer, please refer to the sticker on your hitch indicating the maximum rating. This chart is to be used as a guide only. Consult the hitch manufacturer for more information concerning your specific needs.

CAMPING

CAMPSITE SELECTION

There are many campground guides that will assist you in making your selection. Many campgrounds accept reservations and during peak seasons it is wise to make a reservation. If possible, arrive early so you can inspect and choose your campsite during the daylight hours.

During the winter months it is desirable to take advantage of natural windbreaks like trees, bushes or any similar type of windbreak. This will cut down the possibility of cold drafts that can affect the comfort level of your unit.

SET-UP

It is very important that your unit is level. This allows your refrigerator and drainage systems to operate properly (both function by gravity). To determine levelness, place a level on the bottom of the refrigerator's freezer compartment or in a normally level location inside the vehicle. You may wish to permanently attach levels (available at your dealer) on the front and/or back and sides of the RV. This will allow you to tell at a glance if you've stopped on a level site and will help speed the leveling process.

LEVELING

If the unit needs side-to-side leveling, make a step leveling ramp on the low side out of 1 x 6" or 2 x 6" boards of varying lengths. Pull the unit forward or back onto the leveling ramp until the tire(s) on the low side is level. Many experienced RVers carry level boards or blocks in their unit for this purpose.

WARNING!

- Always be sure the vehicle is level before operating the slide-out room.
- Always be sure there are no obstructions blocking the path of the room when it is moving.
- Always make sure that the room path is clear of people and objects before operating.
- Always keep away from the slide rails when the room is in motion.

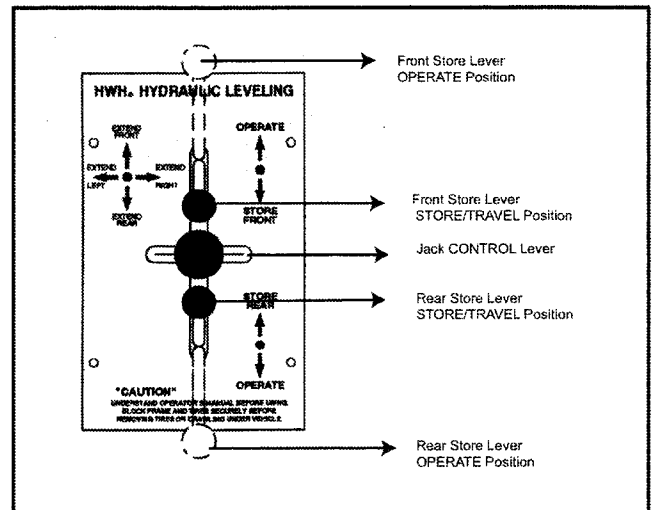

LEVELING JACK CONTROLS

CONTROLS

ON/OFF Switch: This is the ON/OFF switch for the leveling system. It provides control power to operate the electrical relay on the pump and the LEVELING LIGHTS. It does not control power to the four red WARNING LIGHTS, the master JACKS DOWN warning light, or the warning buzzer.

“Store Levers” These two levers are used to retract the jacks into the STORE / TRAVEL position for traveling. The levers must be in OPERATE position for leveling.

“Jack Control Lever” Jacks are extended in pairs by pushing the jack control lever to one of the EXTEND positions. This movement of the lever activates the pump and directs hydraulic fluid to the jacks. When the lever is released, it will return to the neutral (center) position, turning off the pump and stopping jacks in position.

INDICATOR LIGHTS

“ON” Light: This light indicates the system is on.

“NOT IN PARK” Brake Light: If a yellow LEVELING light is on, that indicates a side or end of the vehicle is low. Extend the appropriate jack pairs to deactivate the yellow light. Only one yellow leveling light should be on at a time. The vehicle is level when all yellow lights are out.

“WARNING” Lights: A red WARNING light will be on when the corresponding jack is extended approximately 2 inches or more, provided the ignition switch is in the ACCESSORY or ON position. Some coaches are equipped with a dash mounted master JACKS DOWN light which will be

on when one or more jacks are extended, provided the ignition switch is ON.

“WARNING” Buzzer: A buzzer will sound if a jack is extended 2 inches or more and the ignition switch is ON.

SITE SELECTION

Park with the front of the vehicle facing downhill if possible. If parked on soft ground or asphalt paving, wood blocks or pads should be placed under the jacks

ROOM EXTENSION PROCEDURES

IMPORTANT: IF THE VEHICLE IS EQUIPPED WITH A SLIDE ROOM EXTENSION, READ THIS SECTION CAREFULLY.

- The wheels **MUST** be blocked securely
- Do **NOT** operate any room extension until the leveling and stabilizing procedure is complete.
- Do **NOT** retract the leveling system until all room extensions are retracted.
- **NEVER** operate the leveling system when any slide rooms are extended.

IMPORTANT: DO NOT USE A ROOM EXTENSION SUPPORT WHEN THE VEHICLE IS SUPPORTED BY THE LEVELING SYSTEM

Leveling Procedure

1. Place gear selector in the parking position, apply the park brake and block tires securely.

NOTE: IF THE HAND/AUTO PARK BRAKE IS NOT SET, THE “NOT IN PARK” BRAKE LIGHT WILL COME ON. WHEN THE “ON/OFF” SWITCH IS ON, THE PUMP WILL NOT RUN IF THE PARK BRAKE IS NOT SET.

2. Turn ignition switch to **ACCESSORY**.
3. Push the **ON/OFF** switch to the **ON** position. The **POWER ON** light will be lit.
4. Move the **FRONT** and **REAR STORE LEVERS** to the **OPERATE** POSITION. Nothing should happen at this time. Place pads under jacks if necessary.

NOTE: THE REFLECTIVE RED “WARNING” LIGHT WILL COME ON WHEN A JACK IS EXTENDED 2 OR MORE INCHES.

5. A lit yellow “**LEVEL**” light indicates that the end, side or corner of the vehicle is low. Only one yellow **LEVEL** light should be illuminated at a time. If a corner of the vehicle is low, a side **LEVEL** light will be on by itself. Move the **JACK CONTROL LEVER** to the extend position to extend jack pairs

corresponding to the illuminated yellow light. Extend jack pairs accordingly until all yellow lights are out. It may take several movements from side to front, or side to rear to raise a low corner.

NOTE: IF THE GROUND IS TOO UNEVEN, THE JACKS MAY NOT HAVE ENOUGH STROKE TO LEVEL THE VEHICLE. THE VEHICLE MAY HAVE TO BE MOVED.

6. After the vehicle is level, the jacks not used for leveling may be extended until they touch the ground. This provides additional stability against wind and activity in the vehicle.

NOTE: DO THIS BY PUSHING THE JACK CONTROL LEVER TO THE REAR AND/OR FRONT AS NEEDED TO EXTEND ANY REMAINING JACKS. DO NOT USE THE RIGHT OR LEFT EXTEND POSITIONS.

7. Push the **ON/OFF** switch to the **OFF** position.
8. Turn the ignition switch off.

NOTE: THE LEVELING SYSTEM SHOULD BE CYCLED ONCE A MONTH OR WHENEVER THE VEHICLE IS USED, TO KEEP THE SYSTEM IN OPERATING CONDITION.

Retract Procedure

CAUTION: BE SURE PEOPLE AND EQUIPMENT ARE CLEAR OF THE VEHICLE

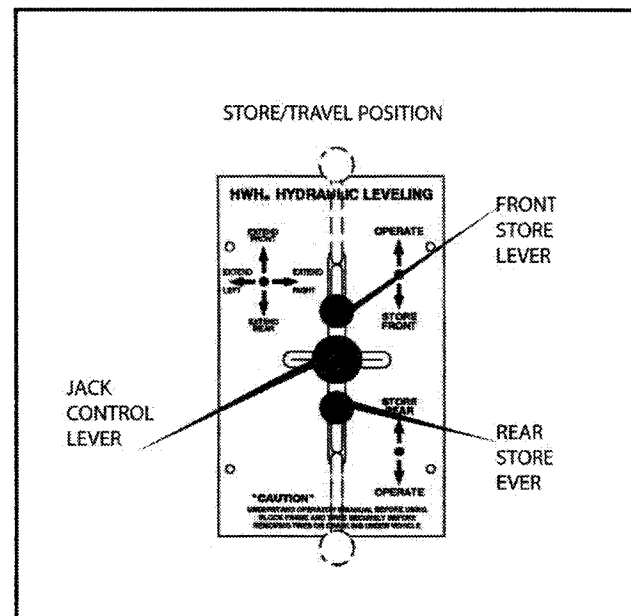

LEVELING JACKS CONTROL PANEL (EXAMPLE)

CAUTION: THE STORE LEVERS SHOULD BE KEPT IN THE “STORE” POSITION WHILE TRAVELING TO KEEP THE JACKS IN THE STORE/TRAVEL POSITION

1. Move the STORE LEVERS to the STORE/TRAVEL POSITION.
2. Visually check that all jacks are in the STORE/TRAVEL position. With the ignition switch in the ON position, the red WARNING lights, the master JACKS DOWN light and the buzzer should be off.
3. Push the ON/OFF switch on the panel to the OFF position. Turn the ignition off or proceed to travel.

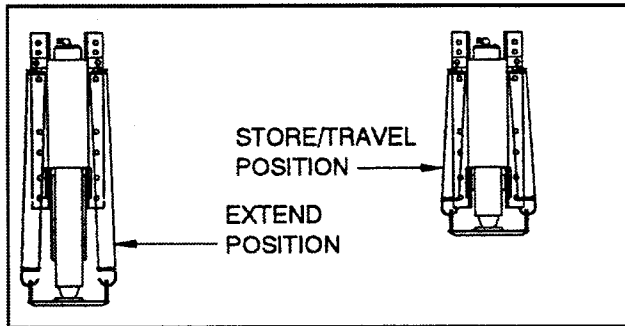

CAUTION: Do not move the vehicle while the leveling jacks are still in contact with the ground or in the extend position.

This vehicle is equipped with straight-acting jacks. Moving the vehicle with the leveling jacks extended can cause severe damage to the jacks and or to the vehicle and create a driving hazard.

Do not rely solely upon warning lights. It is the operator's responsibility to check that all jacks are fully retracted into the STORE/TRAVEL position.

DRIVING YOUR MOTORHOME

DASH CONTROLS

Your motorhome automotive instruments and controls are designed for convenience and safety.

Since dashboards will vary depending on the model and options chosen, read the chassis manufacturer's owner's manual for complete details on operation and maintenance of the systems.

Your Georgie Boy dealer will be happy to acquaint you with the controls in your unit.

Typical components of the dash are as follows:

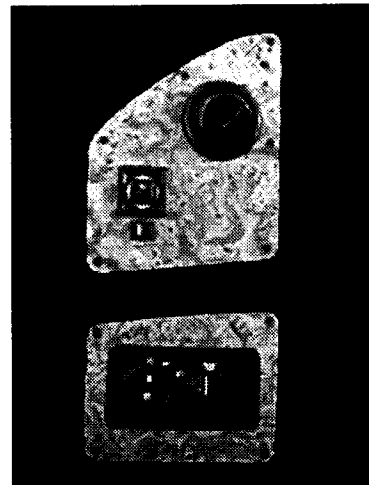

LEFT DASH PANEL (EXAMPLE)

Left Dash Panel

- Air vent
- Mirror control (optional)
- Headlight switch
- 'Step Out' warning light (on models with manual electric step)
- 'Jacks Down' warning light (selected models)
- Emergency Start switch (selected models)

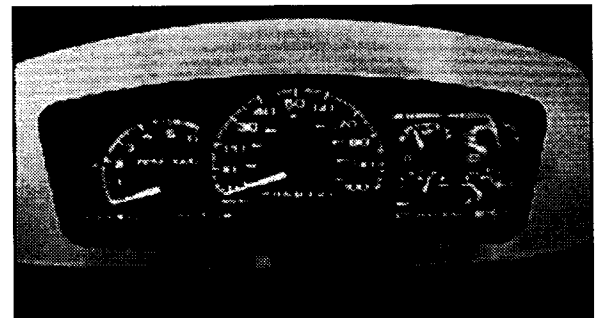

CENTER DASH (EXAMPLE)

Center Dash Panel

Instrument Panel (See chassis Owners Manual)

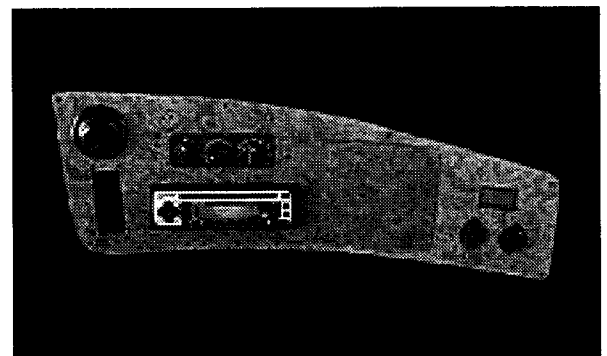

RIGHT DASH PANEL (EXAMPLE)

Right Dash Panel

- Air vent
- Dash air conditioner / heater controls
- Indicator light panel (select models)
 - a. 'Step Out' warning light
 - b. 'Antenna Up' warning light
 - c. 'Jacks Down' warning light
 - d. Daytime running lights.
 - e. Generator
- Dash stereo
- Rear view monitor (optional on select models)
- Glove box (eliminated with rear monitor option)
- 12-volt power outlet(s)
- Emergency Start switch (select models)
- Overdrive switch (Workhorse chassis)
- Defroster fan switch (select models)

Seat Belts

Seat belts are an important safety feature of your vehicle. For your protection, fasten all seat belts when your motorhome is in motion. Adjust the belt low on the abdomen and as snugly as comfort will allow, for greatest safety. Never use a belt for more than one person at a time.

NOTE: ALL OCCUPANTS SHOULD BE FURNISHED WITH AND USE SEAT BELTS WHILE THE VEHICLE IS IN MOTION. DO NOT OCCUPY THE BEDS WHILE TRAVELING AS SAFETY PROTECTION IS NOT PROVIDED.

NOTE: ALL GEORGIE BOY INSTALLED SEAT BELTS MEET FEDERAL REQUIREMENTS.

Infant and Child Restraints

For maximum protection, children should not be transported unrestrained. Infants should be placed in infant carriers. Small children should be restrained in child safety seats. These seats should be placed in the vehicle in accordance with the instructions with the seat or infant carrier.

Clearance

Be sure to read "Clearance Height" signs on overpasses, drive-through windows, etc. Watch out for overhanging tree branches, awnings or similar obstructions that can damage your vehicles' roof or roof-mounted equipment. Check with your dealer for clearance measurements of the unit.

Mirrors

Be sure side view mirrors are positioned properly for best vision. To properly adjust the mirrors, first loosen the locking screw with the allen wrench supplied in the Owners Information package. Adjust the mirrors so you can see along the

side and behind the motor home and retighten the locking screw. The mirrors can then be 'fine tuned' using the electric adjustment switch on the dash. This switch allows you to adjust the mirrors up, down, and side to side. There may also be a rocker switch above the adjustment switch for the heated mirror option

NOTE: DO NOT ATTEMPT TO ADJUST THE MIRROR HEAD WITHOUT LOOSENING THE LOCKING SCREW. DOING SO COULD RESULT IN DAMAGE TO THE MIRROR ASSEMBLY.

OPERATING YOUR VEHICLE

Pulling into Traffic

Check for oncoming traffic in all directions. Signal before entering the flow of traffic. Always accelerate slowly and smoothly; the weight of your vehicle makes quick acceleration not only difficult but potentially unsafe.

Passing

Avoid sudden maneuvers when passing a slower moving vehicle. Remember that additional time and distance are required to pass safely. Wait until the road is clear of oncoming traffic for at least 1/2 mile. Check the outside rearview mirrors and signal lane change. Have safe clearance, signal lane change and return to your original lane.

Braking/Stopping Distance

Allow a safe distance to stop; follow no closer than one vehicle length for each 10 mph. If you start to slide, turn the wheel in the direction of the slide. Do not "slam on" the brakes; a sudden stop may increase the slide.

Added weight requires increased braking distances; motorhome owners must be particularly aware of brake fade hazards. Brake fade is overheating of brake surfaces to the point where friction is greatly diminished, or lost. The result is a brake pedal that is firm to the foot, but produces little or no stopping action.

Proper use of brakes will prevent fade. It normally occurs while traveling downhill grades that require frequent brake application in order to hold speed to the desired level. In an RV, the brakes may become superheated after several applications and an accident may occur. To avoid this problem, use lower gears to retard vehicle speed to the point where only occasional brake application is necessary.

Parking on a Grade

Parking your vehicle on an upgrade or downgrade is not recommended. If it is necessary in an emergency, always apply the foot brake, then set the parking brake before shifting the transmission to neutral.

When preparing to move, shift out of neutral before releasing the parking brake. On severe grades it may be necessary to have a passenger place wheel chocks behind the tires of your vehicle.

Downgrades

When going down long grades, reduce your speed and shift the transmission to a lower gear to assist in braking on long or steep downgrades.

Upgrades

To avoid engine and transmission overheating when climbing a steep grade, reduce speed and shift the transmission to a lower gear.

Overheating

If your vehicles' engine overheats, pull well off the road. Shift to neutral, engage parking brake and run the engine with your foot resting lightly on the accelerator pedal. If the engine does not cool within 2 to 3 minutes, turn it off and locate the problem.

Engine temperature problems may be avoided by following the instructions for Downgrades and Upgrades and turning off the dash air conditioner during those times.

NOTE: PLEASE REFER TO THE CHASSIS OWNER'S MANUAL FOR MORE SPECIFIC INFORMATION.

Swaying or Fishtailing

If this happens while you are towing a vehicle, accelerate slightly and then gradually slow down.

If your vehicle still sways, pull off the road and check the following:

- ...Towing Equipment
- ...Distribution of cargo
- ...Tire pressure
- ...Vehicle front-end alignment and suspension

Turning Corners

Pull several feet farther ahead before turning. This will compensate for the extra width and length of your motorhome and will help you avoid hitting curbs or parked vehicles.

Backing

Remember that your motorhome is higher, wider and longer than other vehicles you may own, so it is very important that you back the RV slowly.

If your unit does not have the optional Rear Back-up Camera, visibility will be somewhat restricted and may require stationing someone beside the unit to guide the drive.

Freeing an Immobile Vehicle

To pull your vehicle out of the snow, sand or mud, apply slight pressure to the accelerator pedal and shift the transmission rhythmically between forward and reverse gear.



Prolonged rocking, even at low speeds, may cause engine overheating, transmission and axle damage or failure, or tire damage.

TOWING YOUR VEHICLE

If your vehicle needs to be towed the following guidelines should be used:

1. The vehicle **MUST** be towed only from the front.
(See *Chassis Operators Manual*)
2. Be prepared to give the tow truck operator at least the following information when you call:
 - Length and height of vehicle.
 - Chassis Manufacturer gross vehicle weight
 - Axle weight ratings.
(This information is found on the vehicle certification label located to the left of the drivers seat.)
3. It is recommended that you ask for an UNDERLIFT (wheel lift or frame lift) type towing assembly for safe towing.

To prepare your vehicle for towing:

- Secure any loose or protruding body parts of the disabled vehicle
- Secure any heavy loose items in the interior.
- Turn off all LP gas appliances and shut off the LP gas tank valve.
- Do not allow anyone to ride in the towed vehicle.

Emergency Towing

CAUTION: DO NOT ALLOW YOUR VEHICLE TO BE TOWED WITHOUT HAVING THE TOW TRUCK OPERATOR READ THIS SECTION AND RELATED SECTIONS OF THE CHASSIS OPERATORS MANUAL.

GEORGIE BOY MANUFACTURING, LLC DOES NOT ASSUME RESPONSIBILITY FOR DAMAGE INCURRED WHILE TOWING.

Speed Control

REFER TO THE CHASSIS OWNER'S MANUAL FOR OPERATION DETAILS



DO NOT use any auto speed control when conditions are not suitable for maintaining a constant speed. Some examples of when **NOT** to use speed control are:

- in heavy or varying traffic
- in strong winds
- on slippery or hilly terrain
- on winding or unpaved roads.

Never shift to Neutral (N) when using the speed control; it will cause the engine to over-speed. Use only properly installed, FCC-approved radio transmitting equipment (such as CB radios). Use of other transmitting equipment may cause the cruise control to malfunction.

Emergency Start Switch

Your vehicle will be equipped with an emergency start switch located on the dashboard. This switch allows you to switch to the coach battery to start the engine in the event of low chassis batteries.

To activate the emergency start, simply push and hold the switch, then start the engine. Once the engine is started, release the switch.

Tire Change

See chassis manufacturer's owner's manual for specific jacking and tire removal instructions. Stop at the nearest service facility to have the torque checked.

Cross Winds

When traveling against strong cross winds, it is best to reduce speed. Remember to steer slightly into the wind when you feel your RV drifting with the cross wind. The key is not to oversteer in this situation.

SLIDE OUT SYSTEMS

LIFTCO SYSTEM

NOTE:

- THE GEAR ASSEMBLY MAY PINCH OR CATCH ON LOOSE CLOTHING CAUSING PERSONAL INJURY.
- INSTALL TRAVEL LOCKS FOR STORAGE AND TRANSPORTATION.
- KEEP PEOPLE AND OBJECTS CLEAR OF ROOM WHEN OPERATING THE SLIDE OUT ROOM

Operating Procedure

Make sure the coach is on level ground with the emergency brake set. Check side clearance. Lower and adjust the stabilizing jacks. Extend the slide-out room by pressing the activator button. Press the button only once, and do not hold the button in the depressed position. Movement of the room may be stopped or reversed by pressing the activator button.

Room Retract Procedure

NOTE: THE PARKING BRAKE MUST BE SET BEFORE A ROOM CAN BE EXTENDED OR RETRACTED.

- Check interior and exterior areas for obstructions
- Insure that no one is inside the slide-out room.
- Depress the activator button.
- Movement can be stopped or reversed by pressing the activator button.
- After the slide room is in position, fully retract the stabilizing jacks.

Manual Room Retract Procedure

USE ONLY WHEN THE ROOM WILL NOT RETRACT WITH THE OPERATOR'S PANEL. FOR NORMAL RETRACT SEQUENCE SEE THE ROOM RETRACT PROCEDURE.

In the event of a loss of electrical power or malfunction the slide-out room is equipped with a manual override. To operate the manual override:

- Check the interior and exterior areas for obstructions.
- Turn the override switch (located on or near the dinette base) to the "OFF" position.
- Locate and remove the manual override plug on the exterior sidewall of the slide-out room.
- Insert the supplied hand crank.
- Turn the crank clockwise to close and crank counter clockwise to extend the room.

LIVING AREA

AIR QUALITY

State-of-the-Art construction and energy conservation methods have been used in manufacturing your Georgie Boy Mfg. These improvements have substantially reduced air infiltration and air exchange, making them

almost airtight. Therefore, regular airing of your unit is recommended, especially during periods of high temperature, high humidity, or after prolonged storage.

CONDENSATION

Condensation can be a problem in modern, tightly constructed, well-insulated RVs. Certain amounts of condensation should be expected, especially on cool surfaces such as windows, roof vents, and metal door frames. However, when there is excessive condensation, the troublesome kind that blocks all windows with fog or frost, damage to walls, woodwork and ceilings can occur.

Remember, sweating windows are a signal indicating moisturing is trying to get out to mix with drier air.

CONTROLLING CONDENSATION

When your unit is closed tightly, especially in cold weather, the small air volume in the RV can absorb only a certain amount of moisture. Bathing, dish washing and laundry appliances are among the causes of excessive moisture in the air. You can control the amount of moisture in the air by:

- Allowing the moisture to escape to the outside.
- Use your vent hood and fan when you cook.
- Keep the bathroom door closed and the vent or window open while you bathe or shower (and for a short time after you have finished bathing or showering, to allow all the moisture to dissipate). Avoid hanging wet clothing in your unit.

TABLES

Listed below are general instructions for setting up the variety of tables and beds that may be found in your RV. Your dealer will be happy to demonstrate these items.

SWING-UP TABLE

To raise the swing up table, pull the table toward you and up; then push it toward the wall. Insert tabs at back of table into the wall brackets. Pull the leg down and adjust to the proper height. To lower the table into the bed position, reverse the above operation.

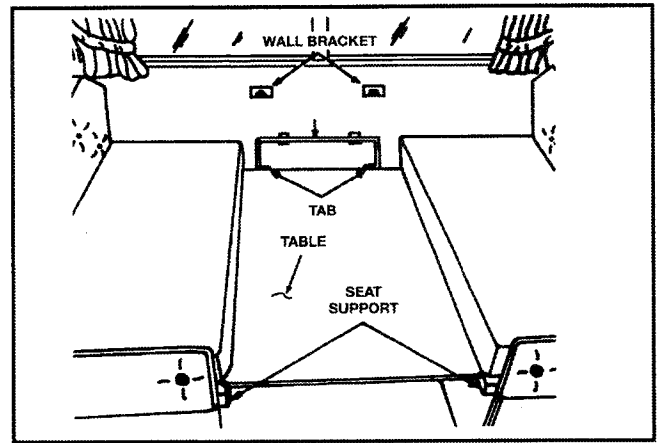

SWING UP TABLE

PEDESTAL TABLE

Insert table leg into base plate. Lower table support bracket onto the leg.

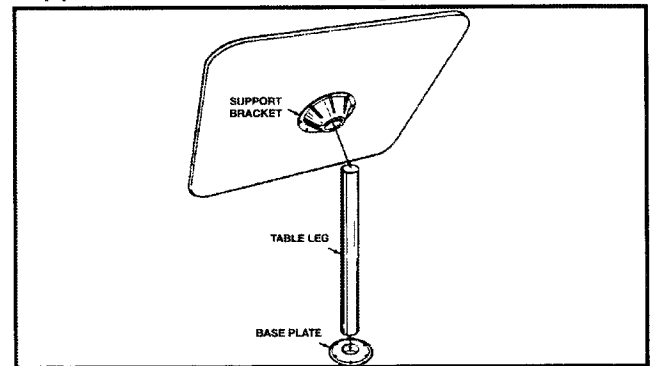

PEDESTAL TABLE

LOUNGE TABLE

Lift lounge table from its storage location behind the cabinet. Lay it in position across the top of the cabinet. Some pull-up tables have extension leaves.

EMERGENCY EXIT WINDOW

The Emergency Exit Window is located in the bedroom at the rear of the vehicle.

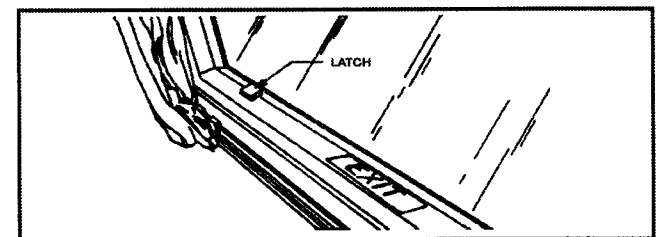

EMERGENCY WINDOW LATCH

To operate, pull out the red handle on each side of the bottom of the window and push the window out.

Important: Before traveling, ensure that all occupants of the vehicle are familiar with the operation of the Emergency Exit. Check the window to be sure it is properly latched.

DRIVER AND PASSENGER SEATS

Some driver and passenger chairs slide, swivel and recline; others may slide and swivel or slide only. All the seats operate manually except for the optional electric drivers' seat. Have your dealer demonstrate the operation of the drivers' seat.

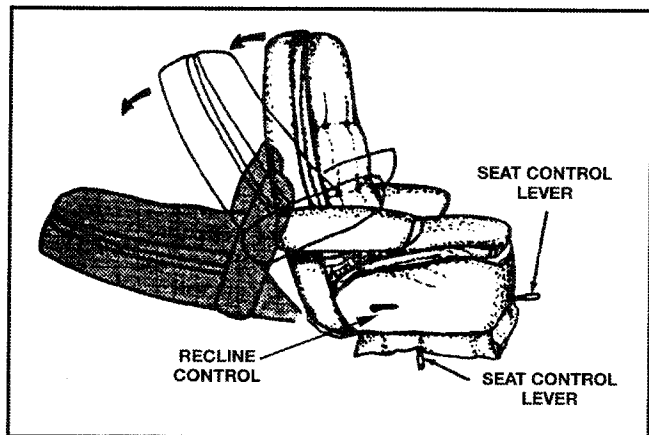

CAPTAIN'S CHAIR

BARREL CHAIRS

To swivel mechanically operated barrel chair, push down on the lever located on the right side of seat and turn seat to desired position. To slide the seat, pull lever located at left front and move seat forward or backward.

BEDS

DINETTE BED

For those with swing tables, move the leg to the UP position and pivot the table down to the dinette seat supports. Place the table on the seat braces and arrange the cushions on the top.

SOFA BED

Several types of sofas are used. Talk to your dealer for proper instructions for the sofa in your particular unit.

SMOKE DETECTOR

The smoke detector in your vehicle is powered by one 9 volt carbon-zinc battery (alkaline batteries may also be used). Use only the following replacement batteries. Use of other batteries may cause a malfunction of the detector

Eveready 216, 1222 or 522
Gold Peak 1604P or 1604S
Duracell 1604

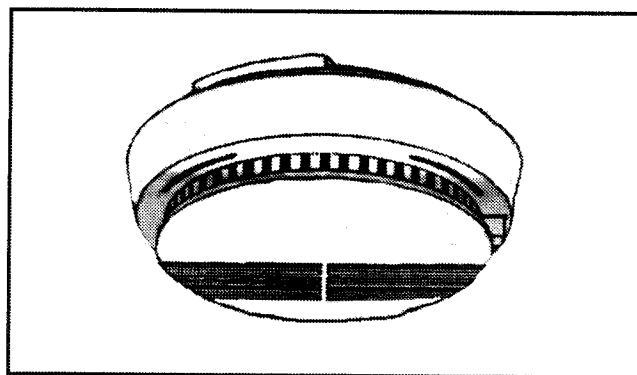

SMOKE DETECTOR (TYPICAL)

The battery should last at least one year under normal operating conditions. When the battery reaches the end of its normal life, a low battery warning (intermittent beeping) will indicate the need for replacement.

Important: Test smoke detector operation after the vehicle has been in storage, before each trip and at least once per week during use.

FIRE EXTINGUISHER

The fire extinguisher is located just inside the main entrance door. Please read the operating instructions that are printed on the fire extinguisher. If there is any doubt regarding operation, you and your family should practice, then replace or recharge the extinguisher.

CARBON MONOXIDE DETECTOR

Your vehicle is equipped with a carbon monoxide detector designed for years of trouble free service. It is powered by the vehicles' battery/converter. If the carbon monoxide level rises above a preset level for a specified number of minutes, the alarm will sound long before a health hazard occurs.

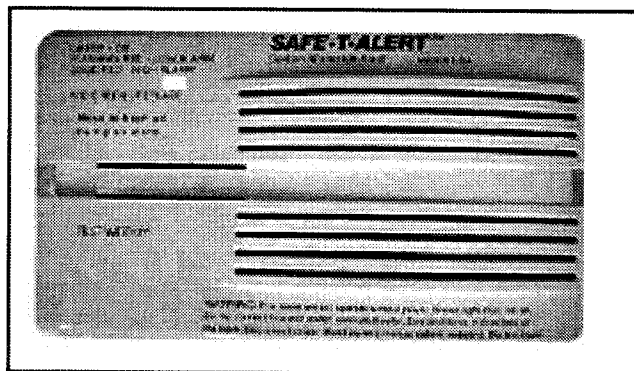

CARBON MONOXIDE DETECTOR

LOW BATTERY WARNING: YOU WILL HEAR AN INTERMITTENT "BEEP" FROM THE CO₂ DETECTOR WHEN YOUR COACH BATTERY IS IN A LOW STATE OF CHARGE.

WINDSHIELD PRIVACY DRAPES

The windshield drapes are designed to provide privacy when parked. They slide along a track over the sun visors and completely cover the windshield when closed. When the drapes are open, secure with tiebacks located on each side of the vehicle.

BASIC UTILITY SYSTEMS

This section describes the four basic utility systems found in your motorhome. They are: Electrical, Fresh Water, Drainage/Sewer and LP Gas. The following will familiarize you with their function, operation and simple maintenance. If a problem should develop with any of the systems, contact your dealer or certified repair center.

Only qualified personnel should perform service or repair on systems or components which affect safety, including:

- The LP System and Appliances
- The Electrical System and Appliances
- Running Gear and Suspensions
- Exhaust Systems

Failure to comply with acceptable working procedure may cause fires, explosions, or other life threatening situations.

(Replacement parts should be equal to the original component part.)

ELECTRICAL SYSTEM

Your motorhome contains two (2) separate electrical systems: one 12-volt direct current (DC) and one 110-volt alternating current (AC). These systems provide you with power while you are camped or are traveling.

The 110-volt systems requires an external source of 110-volt electricity; a campsite or household receptacle or an auxiliary generator.

To reduce the 12-volt load on your RV battery, the 110-volt system should be used whenever a 110-volt hook-up is available. Although most components in your RV (water pump, range hood light and fan, interior lights, etc.) operate only from a 12-volt source, the power converter changes 110-volt AC to 12-volt DC power.

MONITOR PANEL

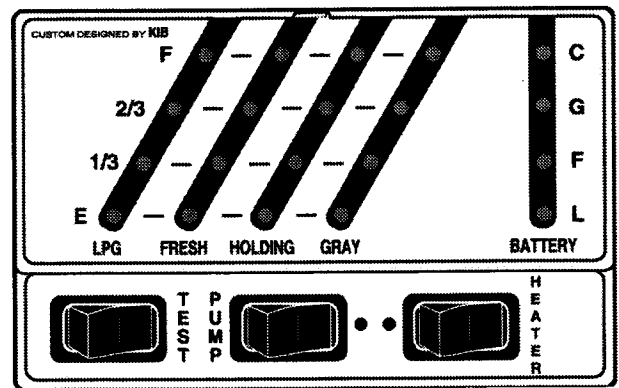

MONITOR PANEL

Your motorhome is equipped with a monitor panel that allows you to check the condition of your RV battery and the volume of fresh, waste and gray water in your unit's holding tanks. It will also monitor LP gas and includes switches for the water pump and water heater.

NOTE: THE BATTERY CONDITION WILL FALL INTO ONE OF THE FOLLOWING LEVELS:

- C CONVERTOR, MORE THAN 14.5 VOLTS .
(UNFILTERED CIRCUIT OR DEAD CELLS IN BATTERY).
- G GOOD, 12.6 - 14.49 VOLTS.
- F FAIR, 12.0 - 12/5 VOLTS .
- L LOW, 5 - 11.9 VOLTS.

Your monitor panel will be located on the wall. Your dealer will be happy to explain the operation of your monitor panel.

110 VOLT SYSTEM

The converter provides 12-volt power for all of the unit's 12-volt components. When the external 110-volt power cord is used, the power is connected directly into the main electrical service panel of the power center and is distributed through circuit breakers.

The 120-volt system supplies power for the following through the power center: refrigerator, exterior receptacles, interior receptacles (used to operate regular household appliances), and optional roof air conditioner.

GROUND FAULT INTERRUPTER / RECEPTACLE

The bath, kitchen and exterior receptacles are protected by a ground fault interrupter (GFI). The GFI is a highly sensitive breaker, built into the bath and kitchen receptacles, and connected to the outside receptacle. It protects against severe electrical shock, if a ground fault occurs in that circuit. The GFI senses the fault

and breaks the bath and exterior receptacle circuits. If this should happen, unplug all appliances on that circuit and reset the breaker in the bath or kitchen receptacle. The GFI system should be tested at least once a month.

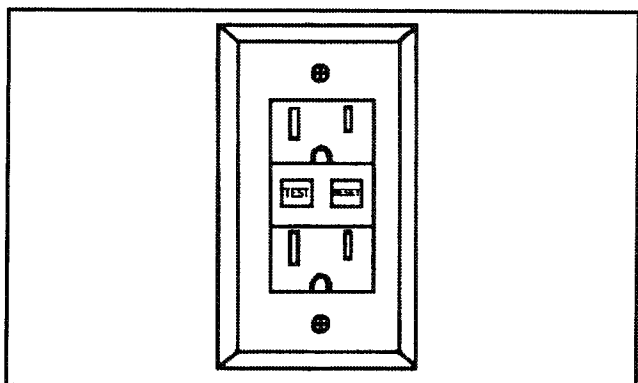

GFI RECEPT

To test the GFI system, plug a test light into the outlet and push the "Test" button on the receptacle. The test light should go out. To restore power, push the "Reset" button. If the button does NOT pop out or if the test light indicates a live circuit, DO NOT use the outlets. Contact your Georgie Boy dealer.

SHORELINE CONNECTION

The shoreline is a heavy-duty cable with a 3-prong grounding plug on one end, permanently attached at the other end, and connected to the power converter. It can be pulled from its storage compartment through a hatch in the sidewall or through a porthole in a storage compartment and connected to a matching receptacle. The 120-volt system is protected by the circuit breakers.

If a circuit breaker opens, unplug the appliance(s) on that circuit, allow a short period for the breaker to cool, and rest the breaker. If the breaker continues to open, it may be caused by an appliance you have added, or a fault in the electrical system. If you determine it may be a fault in the electrical system, contact your Georgie Boy dealer.

50 AMP SHORELINE SERVICE

If your unit is equipped with a 50 AMP service, you will then have a 4-prong plug. This will allow you to operate both roof air conditioners and any other appliances from the shoreline. There will be no selector switches with this option.

CONVERTER

The power converter section of the power center transforms 110-volt AC into 12-volt DC to supply power to all of the 12-volt systems.

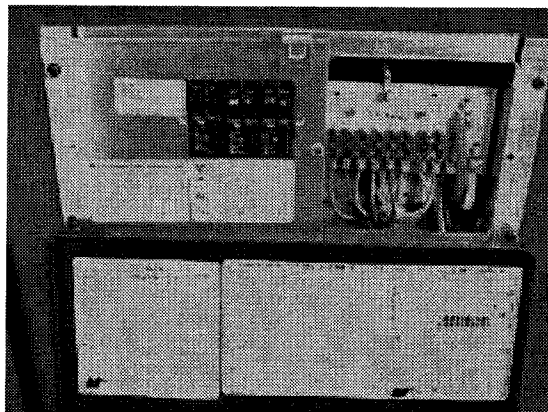

POWER CENTER CONVERTER (TYPICAL)

NOTE: OPERATIONAL INSTRUCTIONS ARE LOCATED INSIDE THE POWER CENTER DOOR.

Each 12-volt circuit is protected by a fuse in the power center. Turn the twist lock to open the door and check the fuses. A listing of the circuits is on the inside of the door.

Some fuses protect circuits with more than one function, others may be for specific appliances. If a fuse is blown, turn off or unplug all appliances on that circuit. Replace the blown fuse with one of the same ampere rating. If the fuse continues to blow, notify your dealer. See the power center manufacturer's manual for specifications, operation and testing procedures.

❖ CAUTION ❖

DO NOT replace a fuse with one of a higher AMP rating.

GENERATOR

The optional auxiliary generator is a gasoline or LP operated component that will supply 110-volt electricity. It can be operated when your vehicle is stopped or while you are traveling. It draws its fuel from the gasoline tank, or LP tank.

The fuel pickup tube is designed so that it can not drain all of the gasoline from the tank. It will not draw fuel below / tank. A labeled remote generator starter switch is provided inside your unit. There is also a START/STOP switch mounted on the generator. An automatic transfer switch incorporated in the power center

prevents the simultaneous use of the generator and the shoreline connection. When the generator is started, the transfer automatically switches from shoreline to generator power.

When the generator is shut down, the transfer automatically switches to shoreline power. Every time you start the generator, there is a 30 to 45 second delay. There are also one or more 30 amp circuit breakers on the side of the generator. Check these breakers if you do not have power after 45 seconds.

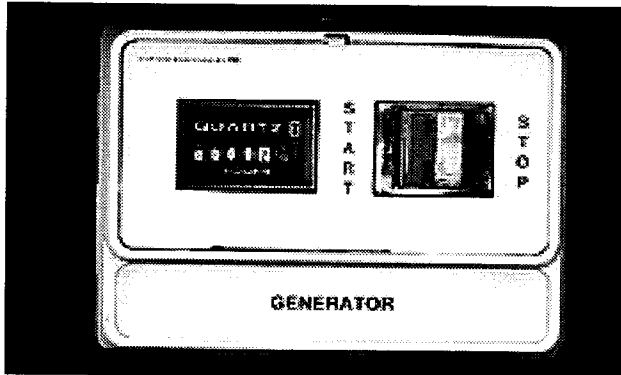

GENERATOR START/STOP SWITCH

12 VOLT SYSTEM

The 12-volt system, which includes the automotive battery and RV battery and the 12-volt converter, supplies power to the exterior lights, range hood fan and light, the furnace blower, water pump, interior 12 volt receptacles, porch light and monitoring panel.

The 12 volt receptacles can only be used for appliances specifically designed for that type of energy. The 12 volt energy is supplied by the automotive battery, the coach batteries or the power converter.

The automotive alternator supplies 12 volt power to the vehicles' lights and components and the vehicles' 12 volt system, including running lights, brakes and appliances, when the engine is running. The automotive alternator also will charge the vehicle batteries.

The vehicles' batteries are charged by the power converter when you are using a Shoreline connection, generator, or external 120 volt power source. To check the battery using the monitor panel, disconnect the Shoreline and turn on at least three interior lights. (A discharged battery will show full charge unless

some electricity is being drawn.) With extremely heavy usage, battery water level should be checked daily

IN-LINE FUSES/RELAYS

12-volt mini circuit breakers are generally located under the step in the entry stepwell or mounted to the firewall behind the passenger headlight in the engine compartment.

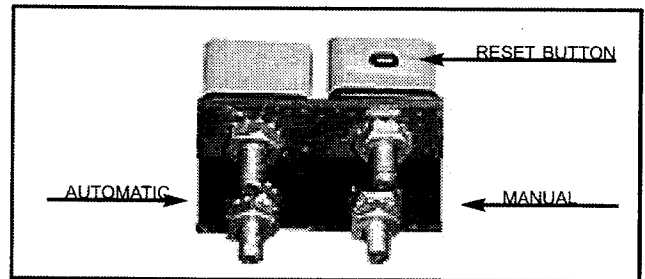

AUTOMATIC AND MANUAL RESET CIRCUIT BREAKER

An 'automatic' reset circuit breaker requires no action since it automatically resets after a short delay. To reset the 'manual' circuit breaker, depress the slightly protruded button (shown in the above picture).

In-Line fuses or over-current protective circuit devices have also been installed directly off the coach battery(s) for additional overload protection.

POWER DISTRIBUTION CHART

CHASSIS BATTERY	POWER CENTER AND/OR 12-Volt BATTERY	120-VOLT ELECTRICAL
Battery disconnect	Battery disconnect	Power center
Starter (engine)	Generator starter motor	All receptacles
Head Lights	All interior lights	Refrigerator
Taillights	Porch light	Air conditioner(s)
Stop lights	Trunk lights	Microwave
Turn signals	Power steps	VCR
Parking lights	Leveling system	Television
Backup lights	Water pump	
Clearance lights	Monitor panel	
License plate lamp	Range vent	
Heated mirrors	Power roof vent	
Dash lights	Jack Pump & motor	
Map lights	Television antenna	
Horn	Water heater	
Windshield wipers	(electronic ignition)	
Backup monitor	Furnace	
Heater fans (front & back)	(electronic ignition)	
Defrost fans	Refrigerator controls	
Radio	Slide-Out Control	
	Wall T-stat	
	CO Detector	
	LP Leak Detector	

FRESH WATER SYSTEM

Fresh water is supplied either by the vehicles' fresh water tank, using the 12-volt demand pump, or by an exterior pressurized source (city water).

Although a common garden hose can be used to fill the water tank and connect to city water, longtime RV'ers recommend a hose specifically manufactured for this, available at your RV dealer.

To fill the fresh water tank, connect a hose to the city water fill. Place the valves in the tank fill position, then turn water on. When tank shows full on the monitor panel, turn water off.

CAUTION: Do not overfill the fresh water tank. Serious damage may occur to the motorhome.

Place valves in normal operation position and remove hose. Turn water pump on, open hot water faucet until water flows. Turn hot water faucet off and repeat with cold water faucet. The water pump should shut off and not come on until a faucet is opened.

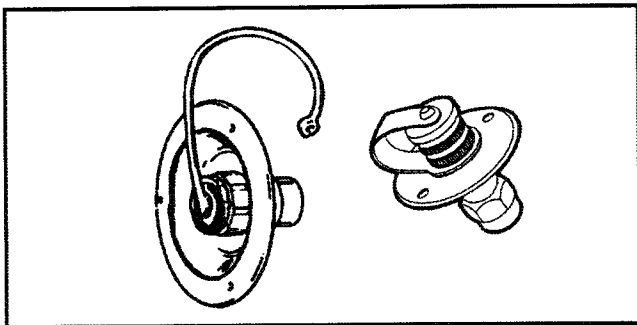

CITY WATER FILL

To use city water, connect a hose to the city water fill. Place the operation valves in the normal position. Turn water on, then open a hot water faucet until water flows. Turn faucet off and repeat with cold water. Water pump should be shut off for city water use.

NOTE: IN AREAS WHERE CITY WATER PRESSURE EXCEEDS 60 PSI, USE A PRESSURE REGULATOR. EXCESSIVE WATER PRESSURE MAY DAMAGE LINES, CONNECTIONS, OR OTHER SYSTEM COMPONENTS.

To add water to the tank when a city water hook up is not available, use the following procedure.

After filling a water container, place the short piece of hose provided into the water (on some units, a plug may have to be removed and the

hose installed in place of the plug). Place the operation valves in the TANK FILLED position, and open the suction fill valve. Turn the water pump on. The pump will draw water from the container into the water tank. You may have to refill the container several times to completely fill the tank.

After tank is full, turn operation valves back to normal position and close suction fill valve, (or valve in line to short hose).

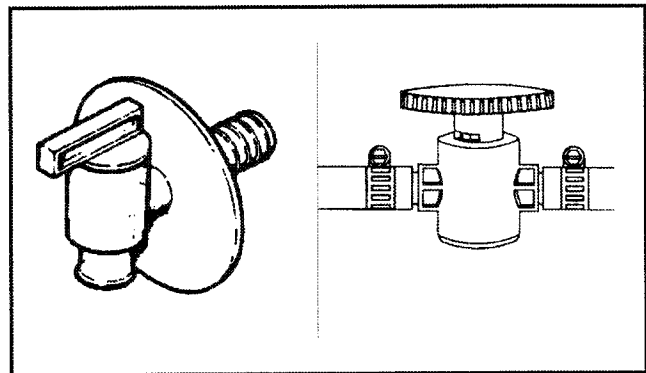

WATER TANK DRAIN VALVES (TYPICAL)

To drain water system/tank, place the operation valves in the tank drain position, open the water line drain valves and open all hot and cold faucets.

SANITIZING THE WATER TANK

Because of a variance in weight distribution, the water tank may be beneath a sofa, dinette, bed or kitchen cabine, or under the floor of the unit. The water tank should be sanitized before you use it for the first time, after a period of non-use, and whenever you suspect the tank may be contaminated. To sanitize your water tank, first empty the tank and then use the following procedure.

1. Mix 2-1/2 cups of liquid household bleach with 10 gallons of water into a potable water container. Follow procedure for adding water to water tank where no city water hook up is available.
2. Turn the vehicle's water pump "ON," open the hot water faucet, wait until the water begins to flow, and then turn the faucet "OFF." Do the same with the cold water faucet. Wait three hours.
3. Open faucets and drains. Drain the entire system. Some solution will remain in the water heater.
4. Connect a hose to the city water fill. Begin filling the tank, Open the hot water faucet. Be sure the water pump is on. Let the water run until the system is completely flushed. Do the

same with the cold water faucet. The hot water faucet will need to run longer to completely drain the water heater.

5. If a chlorine taste lingers, flush the system with a vinegar and water solution (one quart of vinegar to five gallons of water). Wait two to three hours and then flush with fresh water.

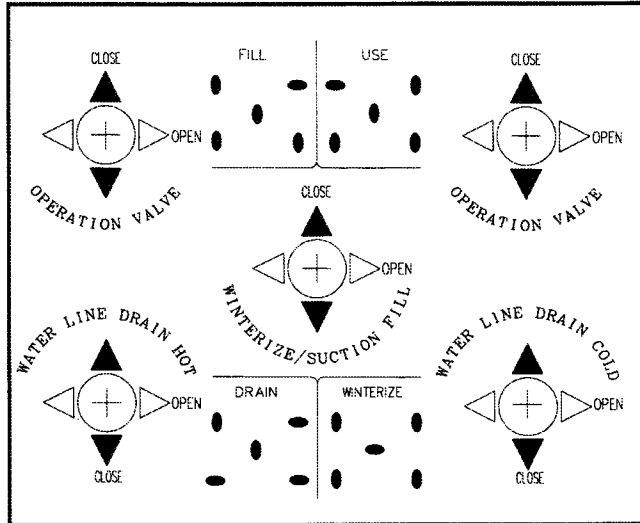

WATER CONTROL PANEL (TYPICAL)

WATER PUMP

The water pump is a 12 volt DC appliance that is activated by a switch on the monitor panel. A second switch may be located at the exterior water compartment.

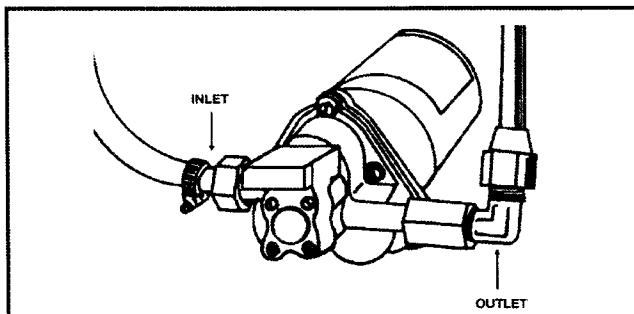

WATER PUMP

The switch can be left on while camping. The pump which supplies water from the fresh water tank will run only as long as is needed, ("on demand" pump). If the pump fails to start when the switch is on, check the fuse located in the converter. If the city water hose is connected, the pump is not required. Refer to the water pump manufacturer's material for additional troubleshooting and winterizing information.

LEAKS

Traveling over bumpy or rough roads can cause

pipe fittings to loosen. Check the pipe fittings in your unit regularly for signs of leakage

DRAINAGE/SEWER SYSTEM

Your vehicle is equipped with a drainage sewer system that functions much the same as the one in your home. This system includes drain lines from the kitchen sinks, lavatory, tub/shower and marine type toilet to a gray-water holding tank and/or a sewage holding tank. The drainage system also includes vents that carry odors (caused by drain water and waste) out through the roof. The drainage system vents also equalize the air pressure, which is necessary to maintain a water barrier against odors in the P-traps and to ensure smooth flow and escape for your drainage system.

TOILET

Flush the toilet before initial use and after emptying the holding tank, this will help to prevent collection of solids.

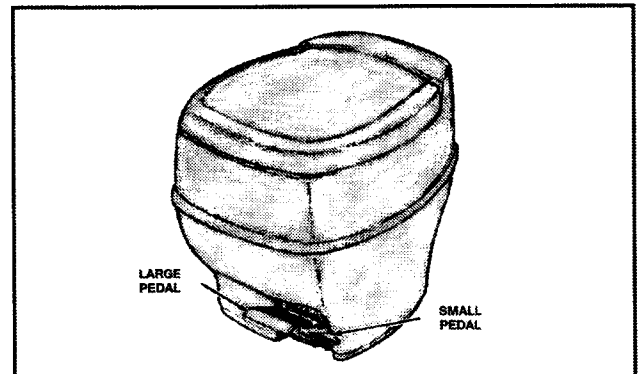

To help control odors, there are a number of toilet and holding tank treatment concentrates on the market. These chemical concentrates are available at your Georgie Boy dealer. To operate the toilet, step on the small pedal to add water to the bowl. When you have the desired amount of water in the bowl, slowly release the pedal. To flush this type of toilet, step on the large pedal until the water swirls and then slowly release the pedal.

When you clean your toilet, do not use highly concentrated or highly acidic household cleaners (no scouring powder). If the pedal does not move freely, apply silicone spray. To ensure proper operation and maintenance, refer to your toilet manufacturer's operating manual.

HOLDING TANKS

Your drainage/sewer system has two holding tanks,

gray water and waste (black) water. The gray water holding tank collects water from the kitchen sink, lavatory and tub/shower. The waste (black) water holding tank is used to collect waste from the toilet. To prevent unnecessary accumulation of solids in the waste holding tank, do not put facial tissues or similar products into the toilet.

NOTE: IT IS HIGHLY RECOMMENDED THAT YOU USE CHEMICALS DESIGNED TO BREAK DOWN THE SOLIDS AND USE ONLY BIO-DEGRADABLE TOILET TISSUE; BOTH OF WHICH ARE AVAILABLE FROM YOUR GEORGIE BOY DEALER.

Holding tanks should be emptied frequently at a dumping station. Most campgrounds have dumping stations, often at each campsite. Many service stations and highway rest areas also have waste dumping stations. Before emptying the holding tanks, be sure your vehicle is level; emptying the holding tanks depends on gravity.

EMPTYING THE HOLDING TANKS

To empty the holding tank, remove the sewage drain hose from its storage area. Remove the cap from the termination outlet and connect the sewage drain hose.

To drain a holding tank, pull the dump valve slide handle. After the tank is drained, close the valve.

Some models have a swivel sewage drain hose holder under the unit. Simply swivel the holder to the desired position, take off the cap and hook up to a dump facility. Now you are ready to pull the gate valves and dump your tank.

While you are camped you may leave the gray water dump valve open only if the hose is connected and your campsite has a sewage hookup. Do not open the waste water dump valve until you want to empty the holding tank. If the waste water dump valve is left open, the rinse and flush water will run off and solids will be left to collect in the bottom of the tank.

After emptying the waste holding tank, flush or pour about two gallons of water through the toilet and drain again. This flushes the tank and helps clean the drain hose. Repeat as necessary.

To empty the gray water holding tank, follow the same procedure used to empty the waste holding tank. When the tank is empty push the dump valve handle in until it seats (if

applicable, lock in place). Remove the hose, wash it and return it to its storage holder. Replace the termination cap securely.

If your model is equipped with an outside shower this may be used to rinse out the inside of your sewer hose before leaving the dump facility

NOTE: IT IS RECOMMENDED THAT YOU ALWAYS DRAIN THE SEWAGE WASTE HOLDING TANK FIRST, AND THEN THE GRAY WATER TANK. THIS ASSISTS IN FLUSHING AND CLEANING THE TERMINATION VALVE AND DRAIN HOSE.

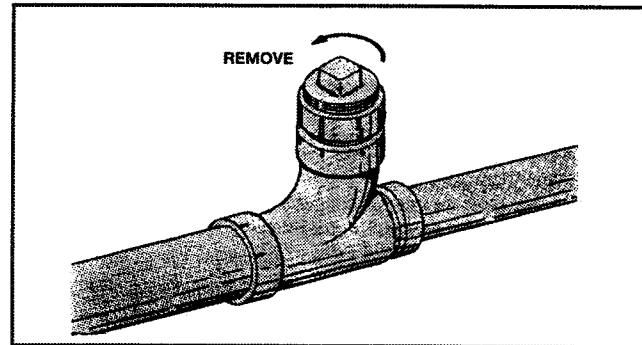

DRAIN CLEAN-OUT

Do not use harsh drain cleaner chemicals or solvents in the drains. Drain cleanouts are installed at intervals to facilitate drain line cleaning or unclogging. Use a wrench to remove and replace drain cleanout plug.

IMPORTANT: DO NOT USE HARSH DRAIN CLEANER CHEMICALS OR SOLVENTS IN ANY PART OF THE DRAINAGE SYSTEM OR TANKS. THIS COULD CAUSE DAMAGE TO THE PIPES AND TANKS.

LP GAS SYSTEM

The liquified petroleum (LP) gas system in your vehicle furnishes fuel for hot water, heat, cooking and refrigeration. LP gas provides a portable, efficient and inexpensive source of energy. It is stored in an LP gas tank which is mounted to the chassis of your motorhome and is serviced through an access door.

Under pressure in the tank, the LP gas turns to vapor; it is the latter that burns. Each tank has an automatic 80 percent stop-fill valve that allows space in the tank for vapor expansion. The tank pressure will vary with temperature and altitude.

❖ CAUTION ❖

The LP gas system is designed and built to meet rigid standards, and it is tested before it leaves the

factory. Your dealer also tests the system before it is delivered to you. Except for simple maintenance and occasional tightening of a connection, always take your vehicle to an authorized dealer for LP gas problems. Always have an authorized LP gas supplier fill your LP gas tanks.

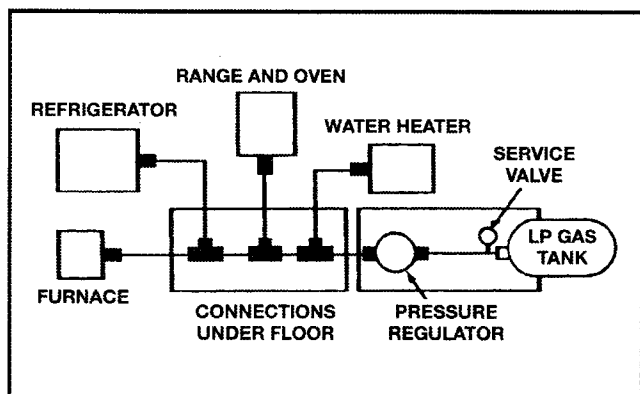

LP GAS SYSTEM (TYPICAL)

❖ CAUTION ❖

LP gas is usually propane or a blend of propane and butane. When fill your tanks, use propane ONLY. Do not use butane or butane mixtures.

❖ CAUTION ❖

LP gas burns readily and with intense heat. With proper care and maintenance, it is safe and efficient. There are, however, certain characteristics about LP gas you should know. LP gas settles into any closed area, it displaces air and could cause suffocation if not detected. It also could create a fire or explosion hazard. In its natural state, LP gas is odorless. An additive gives it a distinctive mustard odor so that leaks can be readily detected.

❖ CAUTION ❖

Under certain circumstances you may not be able to detect LP gas by smell. For that reason, your vehicle is equipped with an LP leak detector which will provide an audible warning if a propane leak is detected. Never disable or bypass this critical safety device.

❖ CAUTION ❖

IF YOU SMELL OR THINK YOU SMELL GAS:

1. Extinguish any open flames, pilot lights, and all smoking materials.
2. Do not touch electrical switches.

3. Shut off the gas supply at the tank. CLOSE valve(s) or gas supply connection.
4. Open doors and other non-electrical ventilating openings.
5. Leave the area until the odor clears, and
6. Immediately call your gas supplier, and have the gas system checked and leakage source corrected before using again.

❖ CAUTION ❖

LP gas containers should not be placed or stored inside the living area of a vehicle. LP gas containers are equipped with safety devices that relieve excess pressure by discharging gas to the atmosphere.

Before using any LP gas appliance, read the respective manufacturer's operating instruction manual.

LP gas appliances used in recreational vehicles are vented to the outside of the vehicle. When parked close to a gasoline pump, it is possible that the gasoline fumes could enter this type of appliance and ignite from the burner flame, CAUSING A FIRE OR AN EXPLOSION. FOR YOUR SAFETY, it is recommended that all LP gas appliances which are vented to the outside should be shut off when refueling.

CLIMATE DIFFERENCES

An appliance will not function if the LP gas does not vaporize. Propane continues to vaporize down to -44 degrees Fahrenheit. Liquid gas does not vaporize as rapidly in cold weather, so you may place too great a demand on your tanks' capacities in certain conditions. This can cause a refrigeration effect resulting in frosting of the tank and regulator. Check with your dealer or LP gas supplier about the appliance demands that can be met by your tank at various temperatures. Always have your LP gas supplier add anhydrous methanol before filling the tank in cold weather.

Propane has become the main type of LP gas used in recreational vehicles. It is recommended that you use only propane gas. The names of LP suppliers can be found in the Yellow Pages of your telephone directory under "Gas-Liquefied Petroleum-Bottled and Bulk." Many campgrounds now have LP fill facilities, as do some service stations.

To operate any LP gas appliance, the LP gas service valve must be open. When first used, or after a refill, there may be some air in the gas lines

that will escape when you first open a range burner or similar LP gas valve. The air may extinguish your match or igniter the first time or two before you get ignition. Remember too, that when you close the tank's service valve some of the gas will remain in the lines.

To completely bleed the lines of gas, close the tank's service valve and light a range burner to use up the excess. When the flame burns out, turn the range burner off.

REGULATOR PRESSURE

Check the LP gas regulator at the beginning of each season or whenever a problem is indicated. Correct line pressure is 11 inches of water column. Your dealer or LP gas supplier can perform this check. LP gas regulators must always be installed with the diaphragm vent facing down. Regulators that are not in compartments have been equipped with a protective cover. Be sure that the regulator vent faces down and that the cover is kept in place. This will minimize vent blockage that could result in excessive gas pressure which could cause a fire or explosion.

LP LEAK DETECTOR

Your RV is equipped with an LP detector designed to detect unsafe levels of LP gas. Be sure not to block the front of this detector, which is typically located near the floor.

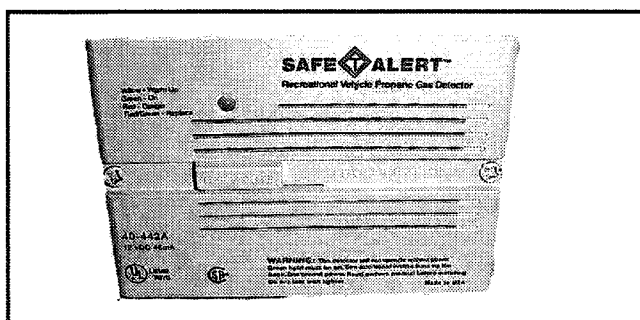

LP DETECTOR

LP GAS REGULATOR FREEZE-UPS

LP gas regulator freeze-up is a problem RV owners can prevent if they are aware of its causes. Although every precaution is taken by fuel producers, tank manufacturers, and LP gas dealers to keep moisture out of the fuel, this problem at times does exist and causes regular freeze-ups. Suggestions that you may want to follow to help prevent this moisture are:

1. Always keep the main tank valve closed during

periods that gas is not in use, especially if the tank is empty.

2. Contact your LP gas dealer about the addition of anhydrous methanol to your tank. Your dealer may do this for a minimal charge, and it will help to prevent freeze-up.

FILLING LP GAS TANKS

Before having a LP gas tank filled, be certain all burners and pilot lights are off. Drive your vehicle to an authorized LP supplier for filling (never remove the tank). He will connect the fill nozzle to the LP gas tank fill valve. When the tank is being filled, the Service valve must be closed and the 20% liquid level gauge must be open. The 80% stop fill valve may close the valve before liquid appears at the 20% liquid level gauge, but if liquid does appear, stop filling immediately. The tank is filled to its liquid capacity. When liquid LP gas is no longer visible, close the liquid level gauge.



Do not use a wrench to tighten the Service valve or the 20% gauge; they are designed to be closed leak-tight by hand. If you cannot hand tighten properly, the valve probably needs repair or replacement.

A **WARNING** label has been located near the LP gas container. This label reads:

DO NOT FILL CONTAINER(S) TO MORE THAN 80% OF CAPACITY. Over-filling the LP gas container can result in an uncontrolled gas flow which can cause fire or explosion. A properly filled container will contain approximately 80% of its volume as liquid LP gas. If the tank is over-filled, have the LP gas dealer bleed out the excess.



***DO NOT** smoke, strike a match, or ignite a lighter when the LP gas container is being filled. A spark or flame could ignite fumes. Be certain all burner and pilot flames are out and Service Valve is closed when filling your vehicle's LP gas or fuel tanks.*

Because there may be some leakage of LP gas when the tank is being filled, we recommend that you drive at least a mile away from the LP gas dealer before you light any pilots or appliances if the scent of LP gas is present. Open the windows and doors and wait 30 minutes. If the

odor is still present, follow the instructions in the LP GAS LINE CHECK section below.

LP GAS LINE CHECK

Regular maintenance of the LP gas system is extremely important to insure the system's safety. All checks and/or repairs should be performed by an authorized service agency who is trained in dealing with recreational vehicle LP gas systems. The system should be checked at least once every 30 days of use or 5,000 miles of travel. If you are using your vehicle in rough terrain situations or traveling over rough roads these inspections should be done more frequently.



- **DO NOT** modify your LP gas system.
- **DO NOT** use open flame or matches to check LP gas line connections
- **DO NOT** use products that contain ammonia or chlorine (most common household soaps). If you detect a leak, shut off the gas and contact either your dealer or the nearest authorized LP gas dealer to have repairs made.
- **DO NOT** attempt repairs yourself.
- **DO NOT** remove components or replace with components that are not of equal value. Failure to follow this warning will void any vehicle warranty. Failure to follow this **WARNING** can result in explosion or fire which may cause injury or death.

APPLIANCES AND ACCESSORIES

RANGE, RANGE HOOD, OVEN

Your motorhome has a three or four burner range and it may have an oven beneath the range. It has a power range hood with fan and light. The range burners and oven are LP gas appliances. Read the range manufacturer's manual carefully for complete details on the operation and care of the range, range hood and oven.



IT IS NOT SAFE TO USE COOKING APPLIANCES FOR COMFORT HEATING.

This warning is to remind you to provide an adequate supply of fresh air for combustion. Unlike homes, the amount of oxygen supply is limited due to the size of the recreational vehicle. Proper ventilation when using the cooking appliance(s) will avoid dangers of asphyxiation. It is especially important that cooking appliances not be used for comfort heating as the danger of asphyxiation is greater when the appliance is used for long periods of time.

Cooking appliances need fresh air for safe operation. Before operation:

- **Open overhead vent or turn on exhaust fan.**
- **Open window.**

Lighting the Pilots

There are pilot burners on all LP gas ovens. All pilot lights are turned on and off by the oven control knob.

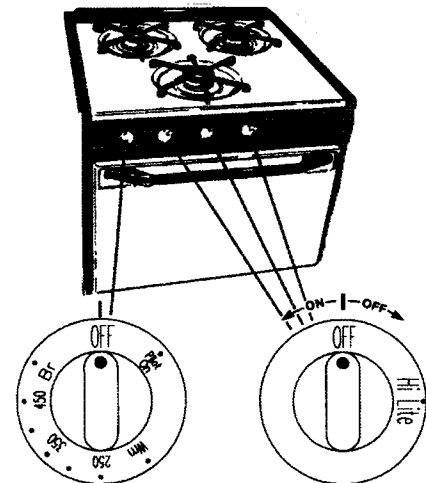

RANGE AND OVEN CONTROLS

Be sure that appropriate knobs are turned off when burners are not in use to avoid the risk of unburned LP gas accumulating in the vehicle. The oven control knob must be in the PILOT'S

ON position for the pilot(s) to be lit. Once lit, the pilot(s) will continue to burn

Lighting the Range

Be certain that the LP gas Service valve is OPEN. Light a match and hold it close to the range burner making sure you are lighting the valve you turned on. Turn the burner's control knob to full ON.

Air in the line may cause a blowing noise and may extinguish the match. When the line is free of air, the burner will light readily. Adjust the burner flame with the control knob.

Care of the Range and Oven

Allow the range top to cool, then clean it with hot, soapy water. Use a damp cloth to clean chrome surfaces. Grease splatters, which may bake onto the surfaces, should be wiped off before they have time to harden. Use chrome polish to remove stubborn stains. Clean the oven with commercial cleaner after each trip, or as necessary. DO NOT apply cleaner to aluminum gas tubing, thermostat sensing bulb or electrical components.

Care of Range Hood

For metal surfaces, use the same procedure as for the range top. For the power hood, clean the plastic light cover by removing and washing it. If the light burns out, replace with a bulb of the same size.

To clean the power hood filter, push slot located in center front of screen and pull down. If not greasy, simply tap the filter to shake out the dirt. If the filter is greasy, run hot, soapy water over it until grease dissolves. Allow the filter to drain and dry, then replace by positioning the flanges and push into place.

MICROWAVE OVEN

The microwave oven is a 110-volt appliance used to cook, defrost or simmer foods in less time than other cooking methods. Several types of microwave ovens are installed by the manufacturer.

Be certain to read carefully the oven manufacturer's owner's manual for specific instructions for the model which may be installed in your unit.

WATER HEATER

Your water heater is an LP gas appliance capable of heating gallons of water to a preset temperature. When the system is connected to city water, fill the water heater by opening a hot water faucet. When filling the fresh water tank, turn the water pump ON and open a hot water faucet. In either case, when water flows steadily, turn the faucet OFF.

Water Heater By-pass

There is a water heater by-pass system installed in the water lines at the back of the water heater. This by-pass system allows you to use the water system without the water heater, as well as winterize the water system without having to fill the water heater with anti-freeze.

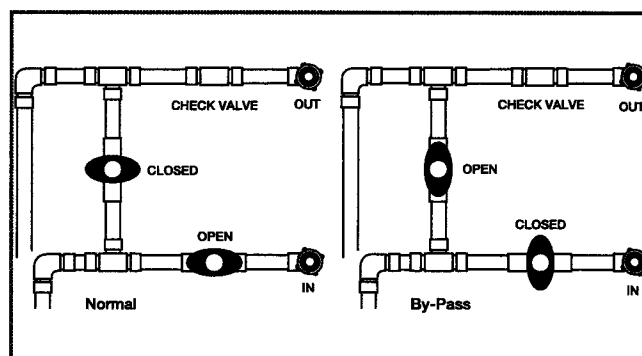

WATER BY-PASS

For normal operation, close the center valve and open the outside valves. To by-pass the water heater, open the center valve and close the outside valves.

Electronic Ignition

Place the remote water heater switch in the ON position. This switch is located in the lower right corner of the display panel. If the red fault light comes on, place the switch in OFF position and wait 5 minutes. The red fault light will only come on in the event of water heater malfunction or if the flame fails to light.

After the required delay, again place switch in ON position. If the water heater turns on a green light will show on the display panel. It may take more than one start attempt when the water heater is being used for the first time or after the LP gas bottle has been

refilled. To turn the water heater completely off place the switch in OFF position.

Burner Adjustment

Refer to Water Heater Operation Manual.

Draining the Water Heater

The water heater has a drain plug or drain cock inside the water heater exterior compartment which must be opened or removed to drain the water heater tank. To facilitate drainage, open all hot water faucets. When water ceases to drain, replace plug. Because of the location of the drain plug, about two quarts of water will remain in the bottom of the tank. This can be flushed as described in CARE OF WATER HEATER listed below.



Hydrogen gas can be produced in a hot water system served by a heater that has not been used for a long period of time (generally two weeks or more). HYDROGEN GAS IS EXTREMELY FLAMMABLE. To reduce the risk of injury under these conditions, it is recommended that the hot water faucet be opened for several minutes at the kitchen sink before using any electrical appliance. If hydrogen is present, there should be an unusual sound such as air escaping through the pipe as the water begins to flow. There should be no smoking or open flame near the faucet at the time it is open. Contact your dealer or the Georgie Boy Service Department at the address on the manufacturer's warranty if you are not certain of what action you should take.

Care of the Water Heater

Be certain the exterior compartment is clean and does not contain combustible materials. Never obstruct the relief valve or exhaust vent. Periodically drain and flush the water heater tank.

To flush the tank, connect a hose to the city water fill. Remove the drain plug from the water heater tank. Run water for several minutes to flush tank. Turn water off and reinstall drain plug.

FURNACE

The furnace is an automatic ignition type and the heat is delivered through a floor duct system. To operate the furnace, turn the switch on the thermostat to the heat position and adjust the

temperature to the desired setting. An automatic relay in the furnace provides a time delay so there will be a pause prior to the start-up of the fan motor. Once the fan motor starts, air will be delivered through the ducts at room temperature.

The furnace will start warming quickly and continue getting warmer. If your motor home is cold throughout, it may take several hours to heat the entire interior and contents to a comfortable temperature. Once reached, your furnace will automatically maintain the set temperature.

On initial lighting, the burner may not ignite due to air in the gas lines. If this occurs, turn the switch back to the heat position. If the furnace does not light after several attempts, while allowing each time for any delay pause, turn the thermostat switch to OFF and contact your authorized Georgie Boy dealer or Service Center.

DO NOT attempt to repair or adjust the furnace yourself; see a certified repair center

Note: Although the furnace's fuel source is LP gas, the power operates on 12-volt electricity. The furnace requires a minimum of 9 volts to operate.

DO NOT use portable fuel-burning heating appliances, including kerosene heaters, wood and charcoal grills or stoves, in your vehicle. Such appliances produce excessive moisture, consume oxygen and may emit dangerous products of combustion.

A combination wall thermostat controls the heating and air conditioning systems.

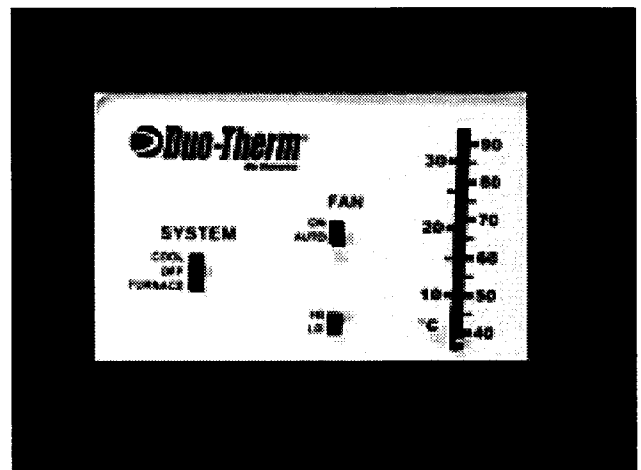

HEAT/COOL THERMOSTAT (TYPICAL)

Preventive Maintenance

Preventive maintenance should be performed annually by an authorized dealer and should include cleaning of heat exchanger, furnace ducts and blower wheels to remove dust, lint and other foreign materials. The furnace's LP gas system should also be checked. Check manufacturer's manual for further information.

Air Conditioner Operation

To operate the ducted roof air conditioner, turn the switch on the wall thermostat to the COOL position and adjust the temperature to the desired setting. The roof air conditioner operates on 110-volt electricity so the motor home must be plugged in to a land connection or the generator must be operating.

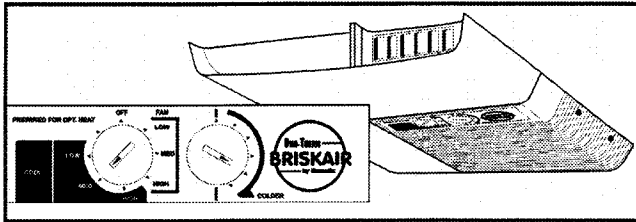

DUCTED ROOF AIR CONDITIONER (TYPICAL)

The air conditioner utilizes ducts in the ceiling to distribute the airflow throughout the motor home. The airflow can be regulated by opening and/or closing the outlets of your choice.

Your motor home may also have a second optional roof air system. If so, it is controlled by a separate wall thermostat, generally located in the bedroom. This auxiliary thermostat will not control the furnace.

There is a filter in the ceiling unit, which should be cleaned periodically. Ask your dealer to demonstrate how to remove and reinstall this filter.

REFRIGERATOR

Operating Instructions

Your refrigerator is two-way (LP gas and 120-volt electricity). It is equipped with a control system, which can automatically select the most suitable energy source which is available, either 120-volt AC, or LP gas operation.

The refrigerator can be run either in a factory preset temperature setting AUTO mode, or in MANUAL mode. The refrigerator controls will work down to 9.6-volt DC.

Ask your Georgie Boy dealer to demonstrate the operation of the refrigerator in your RV. The instructions given here are for your convenience; in case of a difference, use the instructions furnished with your refrigerator.

The refrigerator operates on the gravity flow of chemicals, so it must be level. If you must stop on an uneven site for more than 30 minutes, turn the refrigerator OFF. Use a level in the freezer compartment to check levelness.

Before starting on a trip, use the shoreline connection to cool the refrigerator the night before departing. Keep items to be stored in the RV refrigerator in your home refrigerator or freezer until you are ready to leave. This will reduce the cooling load on your refrigerator and help keep perishable foods fresh longer. Always store food in sealable containers or suitable wrapping. When traveling, switch to LP gas operation. Use door lock during travel.

Some states and municipalities do not allow operation of LP gas systems while the vehicle is in motion. If you have a question in this regard, check with local law enforcement authorities.

Start Up Instructions

- A continuous 12-volt DC supply must be available for the electronic control to function.
- Press the main power ON/OFF button to the DOWN position.
- In AUTO mode operation, the temperature is automatically controlled by a factory preset temperature setting, on the energy source selected by the control system.
- In MANUAL mode operation, the refrigerator will run continuously on the energy source selected by the control system.

NOTE: UNDER CERTAIN COOL WEATHER CONDITIONS THE FOOD IN THE LOWER PORTION OF THE FRESH FOOD COMPARTMENT MAY FREEZE IF OPERATED FOR EXTENDED PERIOD OF TIME ON THIS MOD

Operation Cont'd...

Before starting the refrigerator, check that all the manual gas valves are in the ON position. DO NOT forget the manual shut-off valve on the rear of the refrigerator.

This refrigerator is equipped with an Automatic

Energy Selector (AES) control system, which can automatically select the most suitable energy source which is available, either 120 volt AC, or LP gas operation.

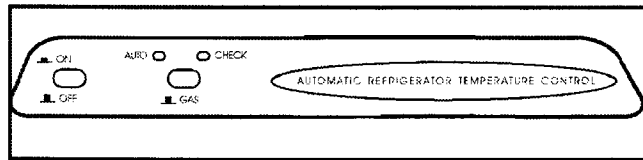

REFRIGERATOR MONITOR PANEL (TYPICAL)

Auto Mode

Press the AUTO/MANUAL mode selector button to the DOWN position. The AUTO mode indicator lamp will illuminate. If 120-volts AS is available, the control system will select AC operation. If 120-volts AC is not available, the control system will automatically switch to GAS operation. Within 45 seconds, the burner should be ignited and operating normally

1. If the CHECK indicator lamp illuminates, the control has failed to ignite the burner on GAS. To reset when the CHECK indicator lamp is illuminated, press the main power ON/OFF button to the OFF then ON position
2. On the initial refrigerator start-up on gas (120-volts AC is not available), it may take longer than 45 seconds to allow air to be purged from the gas line. If the refrigerator has not been used for an extended period of time or if the LP tanks have just been refilled, air may be trapped in the supply lines. Purging air from the lines may require resetting the main power ON/OFF button three or four times. If repeated attempts fail to start the LP gas operation, check to be sure the LP gas supply tanks are not empty and all manual shut-off valves in the lines are open. If the problem is still not corrected, contact a Service Center for assistance.

NOTE: DO NOT CONTINUE TO RESET GAS OPERATION IF THE CHECK INDICATOR LAMP CONTINUES TO BE ILLUMINATED AFTER SEVERAL TRIES.

3. In AUTO mode operation, the temperature is automatically controlled by the factory preset temperature setting.

Manual Mode

Move the AUTO/MANUAL mode selector button to the UP position. The AUTO mode indicator lamp will go off.

The difference from AUTO mode and MANUAL mode operation is the refrigerator will run continuously on the energy source selected by the control system.

To Turn Refrigerator Off

The refrigerator may be shut off while in any mode of operation by pressing the main power ON/OFF button to the up (OFF) position. This shuts off all DC power to the control system.

NOTE: To avoid running out of battery the climate control should be turned OFF. The interior light should also be turned off during defrosting and storage periods. Use a strip of tape to close the light switch or remove the lamp bulb.

Care of Refrigerator

Remove food and ice after each trip. Clean the interior of the refrigerator with a lukewarm, mild baking soda solution. The evaporator, ice trays and shelves must, however, be cleaned with warm water only. Wipe dry with a soft, dry cloth. Never use strong chemicals or abrasives to clean the refrigerator; they can do harm to the plastic and aluminum surfaces. If the refrigerator is not in use for a period of time, turn all power OFF, empty and clean the interior and leave the door slightly ajar.

To defrost refrigerator freezer, remove food and ice. Turn the thermostat OFF. To speed up the defrosting process, fill the ice trays with hot water. When all frost is melted, empty the drip tray and dry the interior of the refrigerator with a clean cloth. Replace the drip tray and ice trays, replace all food stuffs and set the thermostat at MAX for a few hours. Later, reset the thermostat knob to its normal position.

ELECTRIC STEP

Your motor home may have either an automatic (normally a double step) or a manual electric entry step. The automatic step is operated by a switch on the entrance door. The switch will extend the step when the door is opened and retract the step when the door is closed.

There is a switch on the wall just inside the entry door which will allow you to shut off the step or keep the step(s) extended when the motor home is being used. If this switch is left in the OFF position and the motor home is started, there is a safety override switch which retracts the step.

The manual electric step (normally a single step), is operated by a switch just inside the entrance door. To operate the step, simply push the switch in the direction you want the step to go. A light on the dash will alert you if the step has been left in the extend position when you start your motor home.

Maintenance and Lubrication

It is critical to keep the steps free of all mud, salt and road grime and properly lubricated to maintain proper operation. Clean the steps as often as necessary and lubricate all moving parts, including pivot points and linkages every 30 days with a good quality moisture and heat resistant penetrating grease.

VEHICLE MAINTENANCE

STORAGE

You should follow the following procedures if you will not be using your motorhome for an extended period.

LP GAS

Close the LP gas container's Service valve. Extinguish all pilots and close all appliance LP gas valves (oven/range, water heater, refrigerator, furnace).

Light a range burner to consume any gas remaining in the lines. When the flame burns out, turn the range burner off.

WATER HEATER

For information regarding how to drain the water heater, see Water Heater Draining, pages 29 & 30 of this manual.

WATER PUMP

When the water tank and water lines have been drained, remove the outlet hose from the pump. Turn the pump on, allowing it to pump out any remaining water, usually about a cupful. Use a towel or cloth to catch this water. Reattach the outlet hose.

ELECTRICAL SYSTEM

Turn off all circuit breakers at the Power Center. Disconnect all loads from the batteries. Be sure batteries are fully charged.

GENERAL

Close and secure all doors and windows. Open a

roof vent or window slightly to allow circulation, but not so far that rain or snow can enter.

FUEL SYSTEM

During extended periods of vehicle storage (60 days or more), moisture can build up in the fuel tank and fuel system.

It is recommended that a Fuel Supplement be added to the fuel tank, (Sta-bil or equivalent). This will help prevent moisture build up. The additive should be put in the tank before filling.

The tank should be filled prior to storage as a full tank reduces the amount of moisture that can accumulate. The engine should then be run to circulate the additive throughout the system.

WINTERIZATION

Make special preparations for storing your unit in cold winter climates. All systems and components should be inspected and, if necessary, repaired prior to storage. Winterize the motorhome before removing the RV battery.

NOTE: IF YOU WILL BE USING YOUR MOTORHOME DURING COLD WEATHER, BE CERTAIN TO KEEP THE FRESH WATER SYSTEM DRAINED OR USE AN APPROVED, NON-TOXIC RV ANTIFREEZE TO PREVENT FREEZE-UPS. HAVE AN LP GAS SUPPLIER ADD ANHYDROUS METHANOL TO YOUR LP GAS CONTAINERS. CONSULT YOUR AUTHORIZED GEORGIE BOY DEALER FOR MORE INFORMATION.

REFRIGERATOR

Remove all food from the refrigerator, defrost and wash and dry the inside. Prop the door open so air can circulate.

CABINETS

Check the staple foods in your cupboards and remove any that could freeze and be damaged. Leave cabinet and closet doors open a little to prevent a musty odor or mildew.

HOLDING TANKS

The dump valve shafts should be inspected and lubricated. Be sure the dump valves are closed.
CAUTION: DO NOT USE AUTOMOTIVE ANTIFREEZE IN THE WATER OR SEWAGE SYSTEM. IT IS POISONOUS AND ALSO CORROSIVE TO SEWAGE SYSTEM COMPONENTS.

RV BATTERY

Recharge and add water, if necessary. Disconnect the battery cables and store battery in a cool, dry place.

Check regularly and recharge as needed. Do not store battery in an area where possible exposure to extreme heat or sparks can occur. Be sure room is properly ventilated to dispel hydrogen fumes given off by battery.

WINDOWS

Cover with newspaper or cardboard to protect fabrics from fading.

EXTERIOR VENTS

Cover refrigerator and furnace vents with plastic. Inspect all roof vents and replace, if necessary.

CAUTION: NEVER USE APPLIANCES WITH VENT COVERS IN PLACE.

EXTERIOR

Clean and wax, lubricate locks and hinges. Check under the motorhome for any openings which would allow varmints to enter; seal if necessary. Lock all doors securely. Inspect throughout the winter months and remove any snow accumulation from the roof with a long-handled broom or similar tool.

WATER SYSTEM

To winterize the fresh water system, place the valves in the winterize position. Place the short section of hose in a container of RV anti-freeze. Open winterizer/suction fill valve. Turn on pump. The water pump will drain anti-freeze from container into system. This will not put any anti-freeze into the water tank. Turn faucets until anti-freeze appears.

FIRE SAFETY

Prevention is the best form of fire safety. Observe the same precautions in your RV as you do in your home. Use care with any open flame inside of your unit. Follow the instructions previously listed for the care and maintenance, and operation of the various appliances in your motorhome.

Be sure everyone in your party is familiar with the emergency features of the unit, the location of exits and the location and operation of fire extinguishers. It is recommended that a fire drill be conducted on a regular basis to ensure this knowledge.

A chemical fire extinguisher has been furnished

with your unit. Check it regularly to be sure it is ready for emergency use. Immediately replace a fire extinguisher that is discharged or partially discharged. Fire extinguishers are located directly inside the front entrance door on either a cabinet or on the sidewall.

❖ CAUTION ❖

Do not bring or store LP gas containers, gasoline or other flammable liquids inside your RV.

SMOKE DETECTOR

Your motorhome has a smoke detector. Test it after the vehicle has been in storage, before each trip, and at least once a week during the time you actually use your motorhome.

EMERGENCY EXITS

Emergency exits are installed in all models. These will be marked by a label which has one-inch red letters. Handles that must be operated to open emergency exits also will be colored red. Be sure your dealer explains the location and operation of emergency exits to you, and that you inform all members of your party.

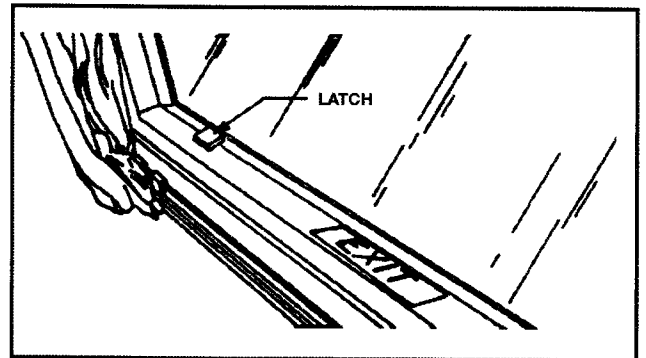

EMERGENCY EXIT WINDOW LATCH

RV MAINTENANCE

Pride of Ownership....RV owners are noted for the pride they take in the appearance of their units. Proper maintenance will do more than keep your motorhome looking nice. It can help ensure trouble-free operation and maximum efficiency of the appliances and accessories.

Failure to maintain the vehicle or its components may also constitute a breach of your warranty obligations. Just as an open window or an unrepaired leak in your home

may lead to costly damage, the failure to repair leaks in your vehicle or to reseal your seams may result in serious damage to your vehicle.

Read the various appliance and component manufacturer's manuals for specific maintenance information. Unless otherwise specified, maintenance functions should be performed, at minimum, on an annual basis.

All maintenance schedules listed are the minimum requirement; heavy use, unusual temperatures or humidity, or other environmental conditions may require more frequent maintenance.

At the start of each season, or after a period of storage, thoroughly inspect and test all systems and components to be certain they are functioning properly before you use your vehicle.

Airing of your motorhome is essential before you occupy it. See details under the AIR QUALITY and CONDENSATION sections.

Automotive and Chassis System of your vehicle should be serviced and maintained as outlined in the chassis owner's manual.

Awning supports and bright metal parts should be cleaned and coated with silicone annually.

Axle and Suspension should be inspected frequently.

Batteries should be inspected frequently and refilled or recharged as necessary; battery cables and terminals should be checked and cleaned every 90 days.

Body should be washed to remove dirt, dust, road tar, bird and tree droppings, insects, and other foreign material from exterior surfaces. Use a mild soap in lukewarm water. Apply an automotive-type wax at least once a year.

Body, Underbelly should be inspected for damage, rust or corrosion every 90 days and repaired as necessary. You may wish to apply undercoating.

Bumper and Frames that are painted, or any exposed painted surface, should be inspected for damage and rust. Rust should be removed

and bumper and frame painted with rust preventive paint annually.

Electrical System should be inspected and tested prior to each trip. Check the shoreline for damage. Test the 120-volt system for proper polarity and voltage. You may want to purchase a ground monitor and a line voltage tester to perform these checks.

Fabrics need regular and continuing care. To keep them at their best, vacuum and brush away loose dirt before it becomes embedded and more difficult to remove. Clean spills and stains while fresh. VELVET fabrics should be cleaned with extreme care. Spills on velvet generally will bead-up. Blot them up quickly and gently so as not to force the stain deep into the fabric. If a stain remains, spot-clean using one of the methods described below. Wipe the stain in the direction of the pile to prevent distortion. When the fabric is dry, gently brush with a soft brush. Many velvet fabrics cannot be cleaned with water-based cleaned agents.

Draperies, Curtains, Bedspreads should be dry-cleaned only.

Cushions, Chairs, Sofas may be labeled with the voluntary industry cleanability code. Because dyes or backings on some upholstery fabrics will be affected by water or solvents, the cleanability code will indicate the cleaning method that is safe for your fabric. If the furniture is not coded, test the fabric for discoloration on an inconspicuous part of the furniture before spot-cleaning. The code is symbolized by the following letters:

W - Use only water-based cleaning agents or foam. Mix two tablespoons ammonia or detergent, such as Ajax liquid, with a quart of water. Wipe the stain gently with a clean cloth dampened with the solution. Continue wiping, turning the cloth so that you are always using a clean portion, until the stain is removed. Be careful not to wet the fabric too much. Always wipe from the outer edge of the stain toward the center.

S - Use only mild, pure, water-free dry-cleaning solvents, such as Energine or Carbona. Dampen a clean cloth with the solvent and follow the same procedure described under W.

WS - Either of the above methods may be used.

X - Clean fabric only by vacuuming or light brushing to remove soil. Do not use liquid cleaning agents of any kind.

TYPES OF STAINS

Water-Based Stains—ketchup, soft drinks, milk, etc. Remove using method W.

Oil-Based Stains—salad dressing, butter, greasy food, etc. Use method S or, for flat-woven fabrics, not velvet, apply Texize K2R Spot Remover according to directions.

Combination Stains—ice cream, gravy, etc. are both watery and oily. Remove these types of stains using the S method and follow with the W method.

Mud Stains—lift away what you can easily remove without forcing the mud into the fabric. Allow the remaining mud to dry completely, then vacuum. If the stain remains, clean with method W.

When overall cleaning is necessary, professional cleaners are recommended. However, if you wish to do it yourself, follow these suggestions:

1. Vacuum thoroughly.
2. Test fabric for discoloration on an inconspicuous place using a foam cleaner such as Fibre Fresh Concentrate or Glamorene.
3. If no discoloration appears, use cleaner on entire item. *Note:* Many velvet fabrics cannot be cleaned with water-based cleaning agents.
4. After cleaning, you may wish to apply Scotchguard fabric protector to such areas as furniture arms, backs and cushions.

NOTE: THE ABOVE INFORMATION IS PROVIDED ONLY AS A SERVICE AND SHOULD NOT BE INTERPRETED AS A WARRANTY. THE LIST OF CLEANING AGENTS DOES NOT CONSTITUTE AN ENDORSEMENT OF PRODUCTS; OTHER SIMILAR PRODUCTS MAY BE EQUALLY EFFECTIVE.

Floor Coverings should be cleaned as necessary. Vacuum carpeting. Avoid using heavy moisture; it could enter and damage your floor.

Hinges should be inspected and lubricated with light household oil periodically.

Locks and Latches should be inspected and lightly lubricated with graphite periodically.

LP Gas system should be inspected and adjusted as outlined in LP Gas section of this manual.

Be certain mounting supports for tanks are secure. Before using, be sure all LP gas orifices and vents are clean.

LP Gas Line Check should be performed frequently. Always check the gas line connection after each refill and inspect the connections regularly, at least every 30 days or 5000 miles of travel.

To check, turn off all burners and pilot lights. Open all doors and windows. Open the LP gas tank.

Service valve and use an approved LP leak detector solution to test all line connections. Bubbles indicate a leak.

NOTE DO NOT USE PRODUCTS THAT CONTAIN AMMONIA OR CHLORINE. TIGHTEN THE CONNECTION WITH TWO OPEN END WRENCHES UNTIL BUBBLES STOP. IF A LEAK PERSISTS, CONTACT YOUR GEORGIE BOY DEALER.

Lug Nuts should be checked every 50 miles for the first 200 miles or whenever a wheel has been reinstalled. If lug nuts continue to loosen, they should be replaced.

Be certain to use the proper torque (450 to 500 ft./lbs.). For more information check Chassis owner's manual.

Rubber Roof

1. For normal cleaning, standard household products may be used such as Fantastic, 409, or a good detergent soap. Be sure to use lots of water and keep sidewalls wet to eliminate possible streaking.
2. For stubborn stains, the use of an abrasive cleaner or scouring powder with a 3M pad (medium) should do the job. Again, be sure to use an ample supply of water.
3. For stubborn stains that resist normal cleaning, on a small area use a cloth dampened with mineral spirits followed by washing with soap and water. Do not use in a large area or allow it to soak.

4. To prevent dirt build up in rubber roof material, you can use a 303 Protectant® available at most RV parts stores.

Note: *Do not put petroleum based products directly on rubber roof mater, or use in large areas.*

If an accident happens and you damage the roof, here is a temporary fix:

Cover the area by overlapping layers of duct tape over the troubled area until a permanent repair can be made by your Georgie Boy dealer.

Seams or Joints should be sealed around the roof, entrance doors, windows, roof wall vents, access doors, storage compartments, roof edges, luggage racks, ladders, air conditioners, TV antenna, radio antenna, satellite dish rails and moldings at least once each year with a similar high quality sealant.

Inspect all seams and joints at least twice a year and reseal as necessary.

NOTE: SOME SEALANTS CANNOT BE APPLIED OVER OTHER TYPES; WHEN PREPARING AREAS TO BE RESEALED, SCRAPE OFF OLD SEALANT.

Clean metal areas with a vinegar and warm water solution. Clean fiberglass areas with mineral spirits before applying new sealant.

Shades, Blinds and Valances should be vacuumed or wiped with a damp cloth.

Sinks in the kitchen and bathroom should be cleaned with a cleaner that is non-abrasive.

Stainless steel and porcelain cleaner may be purchased at most grocery stores.

ABS cleaner may be purchased from your Georgie Boy dealer.

Steps

Should be inspected annually. Remove rust; paint steps and lubricate all moving parts.

Tires

Should be checked for damage and proper inflation prior to each trip.

TV Antenna

Exterior moving parts should be lubricated periodically.

Vents should be inspected and cleaned annually. Lightly oil all moving parts. Inspect vents periodically for bird nests.

Vinyl Coated Ceiling and Walls

Should be cleaned with a mild soap and damp sponge as needed.

Water Heater

Control compartment should be kept clean and free of combustible material and flammable liquids.

The vent and combustible air grille should be clear of any obstructions.

Manually operate the pressure relief valve at least once a year. Operate only when storage water in tank is cool.

Periodically compare main and pilot burner flame with illustrations in manufacturer's operation instruction manual.

Do not tamper with the pilot orifice to increase the pilot flame size; this can cause high water temperature and failure of gas control.

Windows, Doors and Compartment Doors

Should be inspected for damage or leaks prior to each trip.

Replace any damaged or worn parts. Fix or replace any leaking parts.

Lubricate moving parts and rubber seals with silicone lubricant. Clean dirt and debris from window tracks.

Wood Cabinetry

Should be protected and cleaned several times a year using any good non-silicone wood polish.

Careful control of temperature and humidity will help reduce expansion and shrinkage of doors and door panels.

If shrinkage occurs and unfinished parts of the door panels are exposed, cover the exposed areas with matching touch-up stain available from your Georgie Boy dealer.

Appendix A 4 Pre-Travel Check

GENERAL DRIVING CHECKS

For your safety, make certain that the following items have been checked and rechecked before you take your RV on the road. Make certain that all items inside of your RV are secured (e.g., lawn chairs, pots and pans, TV, etc.). As you travel, these items, if not secured, may become damaged or may damage the interior of your RV.

Hydraulic Levelers—Must be raised as far as possible. Visual check is recommended.

Lights—The following lights should be tested: brake lights, warning lights, flashers, clearance lights, taillights and headlights.

Rearview Mirrors—Adjust the rearview mirrors so that the driver can see the right and left sides of the unit.

OTHER DRIVING CHECKS

Whether you are departing from your home, rest area or campsite, you should check the following parts of your unit before you take off.

Tires—Before each trip, check your tires for uneven wear, road damage, foreign objects or excessive peeling or bulging. Each morning, inspect the condition and pressure. Inflate the tire to the recommended pressure (indicated either on the tire or in the manufacturer's instruction booklet). Heat generated by surface friction will increase the tire's air pressure approximately six to nine psi; therefore, do not bleed air out of a hot tire.

Note: Proper tire inflation is extremely important.

A tire should be replaced when:

1. It is worn to 1/16-inch depth in two or more adjacent grooves.

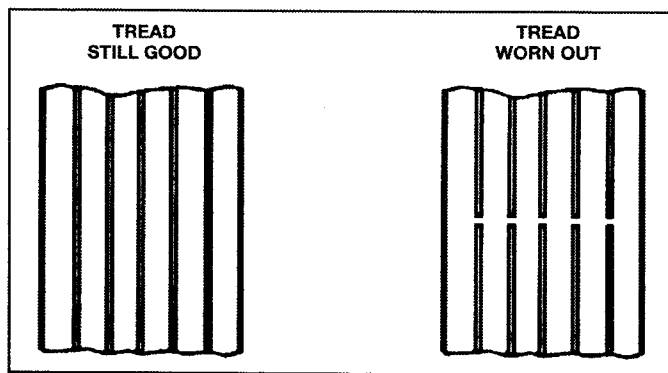

TREAD WEAR INDICATOR

2. It is worn to the level of the tread indicators that are molded into the bottom of the tread grooves, or
3. The indicators appear in two or more adjacent grooves at three locations around the tire.

On new tire purchases, be certain that the new tire is the same size as the old tire and that the new tire has the same ply rating and load range as the old one. DO NOT mix radial-ply tires with bias or bias-belted tires.

Tire Change—Change a tire on as level and firm a surface as possible. If you are on the roadside, activate the vehicle's warning flashers. Apply parking brake and move transmission selector to Park (P). Set up flares and/or warning lights. See the chassis manufacturer's owner's manual for specific jacking and tire removal and replacement instructions which pertain to your unit. Stop at the nearest service facility and have the torque checked.

❖ CAUTION ❖

NOTE: NEVER PLACE THE JACK UNDER A BUMPER OR EDGE OF THE SIDEWALL. USE THE JACK ONLY FOR CHANGING TIRES. NEVER GET UNDERNEATH THE VEHICLE WHEN USING THE JACK; ALWAYS SECURELY STOW THE SPARE TIRE IN THE PROPER AREA AND RETURN ALL JACKING EQUIPMENT TO ITS PROPER STORAGE AREA.

Wheel Lugs—Wheel lugs must be tightened every 50 miles for the first 200 miles whenever a wheel has been reinstalled. Thereafter, check lugs after storage.

Power Cord—The 120-volt shoreline power cord must be unplugged from the external source and placed into its compartment. The cord hatch must be secured before you travel.

Water Fill Hose(s)—All hoses must be disconnected and all hose caps must be secured before you travel.

Sewage Termination Valves—These valves must be closed and locked before you travel. The sewer hose must be removed from the termination valve outlet and stored in the appropriate compartment. Termination caps must be securely fastened to the termination valve outlet(s).

Door Step—The door step (Figure 10, Page 55) must be returned to its travel position before the unit is safe for traveling. To do this, lift the front edge of the step and push it under the unit.

Note: Optional electric steps automatically retract.

Windows and Vents—All windows and vents should be closed completely or adjusted as desired before you travel.

TV Antenna—The TV antenna must be cranked down to its traveling position.

Automotive System—The automotive system of your vehicle should be serviced and maintained as outlined in the chassis owner's manual.

Interior Doors and Drawers—Close and secure all interior doors and drawers in your unit. Store or secure all loose items.

Exterior Access Doors—Exterior access doors for storage and equipment should be closed and locked.

Appendix B ✓ Travel Preparation Checklist

CLOTHING

Underwear
Socks
Shoes, sandals, boots
Shirts
Blouses
Trousers
Slacks
Dresses
Shorts
Sweaters
Jackets
Coats
Rainwear
Swim wear
Pajamas

TOOL CHEST

Screwdrivers
Pliers
Hammers
Tire pressure gauge
Small level
Electrical tape
Masking tape
Wrenches
Allen wrench
Furnace duct tape

CAMPSITE COMFORT

Dishwashing soap
Dishcloths
Dishtowels
Garbage/trash bags
Mop
Broom
Vacuum cleaner
Dust pan
Paper towels
Foil or plastic wrap
Throw rug

SAFETY

First-aid kit
Flares
Reflectors
Tow rope and/or chain

ADDITIONAL TOOLS

Hatchet
Shovel
Saw
12-volt portable tire pump

SLEEPING GEAR

Sheets
Pillow cases
Mattress pads
Blankets
Pillows
Sleeping bags

PERSONAL COMFORT

Towels
Washcloths
Toilet paper
Soap
Toothbrush
Toothpaste
Personal toiletries
Scissors
Sewing kit
Ash trays

MEAL PREPARATION

Bottle opener
Can opener
Matches
Pots, pans, skillets
Plates
Glasses and cups
Silverware
Hot pads
Knives, spatula, etc.
Baking pans
Coffee maker
Toaster
Plastic containers

ENTERTAINMENT

Books/magazines
Binoculars/telescope
Camera, film, flash
Tape player/tapes
Toys/games
Playing cards
Television
Radio

MISC. EQUIPMENT

Bucket
Fuses
Fresh water hose
Check type water hose fitting
Flashlight
20-ft. 3-prong power cord
3-prong adapter with
grounding wire
Wheel chocks, leveling
ramp, blocks or jack
stands
Coat hangers
Folding lawn chairs

Appendix C ✓ Troubleshooting Guide

NOTE: Use the manufacturers' owner's manuals for all appliance trouble shooting.

PROBLEM	CAUSE	SOLUTION
ELECTRICAL POWER		
No electrical power to unit. shoreline.	Shoreline connection.	Make sure you have power to the
	Circuit breaker (120V) may be off or tripped.	Reset breaker(s) at power center.
	Circuit breaker (12V) may be tripped.	Reset breaker at battery compartment.
POWER CONVERTER		
Converter makes a clicking noise.	Circuit overload.	Reduce load on circuit.
	Reversed polarity at battery.	Correct polarity at battery.
	Short in recharge line.	Locate and fix short.
ELECTRICALLY CHARGED (HOT) CHASSIS		
Chassis is electrically charged.	Short in 110/120 volt circuit.	Disconnect unit from electrical supply. Have unit inspected and repaired if necessary, by a qualified service facility. <i>NOTE: Determine if shoreline has proper polarity.</i>
	Power cord ground wire removed.	Make sure shoreline post ground is earth ground and power cord ground is used.
LIGHTS		
Lights flickering.	Loose fuse holders.	Tighten or replace fuse holder.
	Blown fuse.	Replace fuse with one of the same ampere rating.
	Broken connection or wire.	Replace connection and/or wire.
	Bad ground.	Make sure ground connection is secure.
	Converter overheating.	Let converter cool down, reduce load.
Lights dim or half bright.	Bad battery.	Check battery condition.
	Possible converter malfunction.	Have converter checked by an authorized service center.
	Possible low voltage from shoreline.	Make sure voltage to shoreline is not too low.

PROBLEM**CAUSE****SOLUTION**

NOTE: Use the manufacturers' owner's manuals for all appliance trouble shooting.

OUTSIDE RECEPTACLE

No power to outside receptacle.	GFI breaker switch may be off or tripped.	Reset GFI at receptacle.
	Bad power source.	Make sure you have power to the shoreline.

GENERATOR

Generator cranks but will not start.	Generator may be out of gas.	Check the fuel.
	Generator may be low on oil.	Check the oil.
Generator starts but no power.	Fuse on the generator may have blown.	Replace fuse with one of the same ampere rating.
	Breaker switches may be off or tripped at generator.	Reset breaker.
	Circuit breaker may be off or tripped inside power center.	Reset main breaker.

RV BATTERY

RV battery boiling.	Water low in battery.	Refill water to correct level in battery.
	Bad battery.	Replace battery.
	Defective converter.	Have converter checked by an authorized service center.

RUNNING LIGHTS

No running lights.	Blown fuse.	Replace fuse with one of the same ampere rating.
	Bad bulbs.	Replace bulbs.
	Bad ground (rear only).	Check white ground wire at rear frame.

PROBLEM**CAUSE****SOLUTION**

NOTE: Use the manufacturers' owner's manuals for all appliance trouble shooting.

LP GAS

Smell gas in and/or around unit.	Possible gas leak in system.	<ol style="list-style-type: none">1. Extinguish any open flames, pilot lights and all smoking materials.2. Do not touch electrical switches.3. Shut off the gas supply at the tank valve(s) or gas supply connection.4. Open doors and other ventilating openings.5. Leave the area until odor clears.6. Have the gas system checked and leakage source corrected before using again.
----------------------------------	------------------------------	--

WATER PUMP

Pump fails to start when the switch is on.	Fuse located in the converter may have blown.	Replace fuse with one of the same ampere rating.
	System hooked up to city water fill.	Disconnect hose from city water fill (do not need to use pump).
Pump continues to operate whether the faucets are open or closed.	Water tank may be empty or there might be a leak in the system.	Fill water tank and/or fix any leaks in the system.
Pump goes ON and OFF with faucets shut OFF.	There may be a leak in plumbing system fittings or lines.	Fix any leaks in plumbing system, by checking all fittings for tightness and replacing any broken parts.

WASTE TANK

Waste tank will not drain.	Build-up in tank.	Check for build-up in tank at stool. Make sure stool holds water.
----------------------------	-------------------	---

TERMINATION VALVE

Termination valve leaks.	Debris blocking valve or build-up.	Clear debris from and around valve.
	Bad gasket.	Replace gasket.

MICROWAVE OVEN

Microwave oven will not operate.	No power to oven.	Check power supply and circuit breaker.
	Door open, or timer OFF.	Close door and turn timer ON.

PROBLEM**CAUSE****SOLUTION**

NOTE: Use the manufacturers' owner's manuals for all appliance trouble shooting.

FURNACE

Furnace does not light.	May be out of LP gas.	Check the LP gas supply.
	Low battery or bad battery.	Refill water to correct level in battery; recharge battery and/or replace battery.
Furnace does not light and fan does not run.	Blown fuse.	Replace fuse with one of the same ampere rating.
The furnace does not light after several attempts. 		1. Turn the thermostat and the furnace gas control valve OFF.
		2. Contact your Georgie Boy dealer or authorized service center. DO NOT attempt to repair or adjust the furnace yourself.

REFRIGERATOR

Refrigerator will not cool.	Unit not level.	Make sure unit is level.
	Upper and/or lower refrigerator vents clogged.	Clear vents of all debris.
	If on gas, empty tank.	Fill LP gas tank.
	Blown fuse	Replace fuse with one of the same ampere rating.

TV ANTENNA

TV antenna has poor reception.	Power jack not turned on.	Turn power jack switch on.
	Bad connections at TV or wall plate.	Make sure the connections are good at both TV and wall plate.
	Cut or nicked cable.	Replace bad cable where needed at TV and antenna.
	Antenna not pointed in direction of "sending" station.	Point antenna in direction of "sending" station.

Maintenance Schedule*

ITEM	Every Trip	Every 30 days or 1,000 miles	Every 60 days	Every 90 days or 2,500 miles	Every 6 months or 5,000 miles	Annually or 10,000 miles	REFERENCE
Airing	•						Air Quality, Condensation, Maintenance, this manual
Appliances	•					•	Appliances, this manual; Appliance Manufacturer's instructions
Awning Supports						•	Maintenance, this manual
Automotive System	•						Chassis Manufacturer's manual
Auxiliary Heater (Rear)	•		•				Maintenance, this manual
Batteries	•	•					Maintenance, this manual;
Brakes & Suspension					•	•	Maintenance, this manual; Brake & Suspension Manufacturer's manual
Body					•		Maintenance, this manual
Bumpers						•	Maintenance, this manual
Counter, Table Tops	•						Maintenance, this manual
Doors				•			Maintenance, this manual
Electrical System	•						Maintenance, this manual
Fabrics						•	Care of Fabrics, this manual
Floor Coverings	•						Maintenance, this manual
Frame						•	Maintenance, this manual
Hinges						•	Maintenance, this manual
Locks & Latches						•	Maintenance, this manual; Lock/Latch Manufacturer's manual
LP Gas	•	•					LP Gas; this manual; Appliance Manufacturer's instructions
Lug Nuts	•						Maintenance, Chassis manual
Roof, Body, Underbelly				•			Maintenance, this manual
Seams (Seal)						•	Maintenance, this manual
Shades, Valances	•						Maintenance, this manual
Steps	•					•	Maintenance, this manual; Step Manufacturer's instructions
Tires	•					•	Pre-Travel Check, Maintenance, this manual; Tire Manufacturer's manual
TV Antenna		•					TV Antenna Manufacturer's instructions
Vents						•	Maintenance, this manual; Vent Manufacturer's instructions
Vinyl Ceiling & Wall Panels	•						Maintenance, this manual
Water Heater	•					•	Maintenance, this manual; Water Heater Manufacturer's manual
Windows	•						Maintenance, this manual; Window Manufacturer's instructions
Wood Cabinetry	•		•				Maintenance, this manual

* Maintenance schedules listed are minimum requirements; heavy use, unusual temperatures or humidity, or other environmental conditions may require more frequent maintenance.

Appliance Identification Form

Should one of the appliances require warranty service, you will have to identify the manufacturer, model designator and serial number. Fill in this form as soon as possible. It will help you meet identification requirement. Depending on your unit, certain items listed below may be offered as either optional and/or standard. Most of this information can be found on the Recreational Vehicle Data Card attached to the inside of one of the kitchen cabinets.

EQUIPMENT	MANUFACTURER	MODEL DESIGNATOR	SERIAL NUMBER
Automotive Air Conditioner	_____	_____	_____
Converter	_____	_____	_____
Electric Water Pump	_____	_____	_____
Furnace	_____	_____	_____
Generator	_____	_____	_____
VCR/VCP	_____	_____	_____
Keys—Door	_____	_____	_____
Exterior Storage	_____	_____	_____
Other	_____	_____	_____
Microwave Oven	_____	_____	_____
Motorhome Body	_____	_____	_____
Motorhome Chassis	_____	_____	_____
Radio/Cassette	_____	_____	_____
Range/Oven	_____	_____	_____
Refrigerator	_____	_____	_____
Washer	_____	_____	_____
Dryer	_____	_____	_____
Roof Air Conditioner(s)	_____	_____	_____
Toilet	_____	_____	_____
TV	_____	_____	_____
TV Antenna	_____	_____	_____
Water Heater	_____	_____	_____

LIGHT BULBS—CLASS A

INTERIOR	Ceiling Light (Mirada)	1141
	Wall/Overhead Lamp (Mirada)	1076 921
	Flourescent Light	Sylvania F8 w/w
	Aircraft Style Map Light	903
	Dash Dome Light	105 12v 120P
	Floor Courtesy Light	SE 194
	Microwave	110v 30w
	Range Hood	110v 30w
	Refrigerator Light	GE 7576
	Range Hood Light	912
	Bullet Reading Light	F1003
	Overhead 120 Volt (Double)	60w
	Overhead 120 Volt (Triple)	25w
	EXTERIOR	Clearance Light
Compartment Light		GE 168
Mirror Signal Light		CE 193
Fog Light		Solite 894
Docking Light		GE H7614 Flood
Porch Light		93
Front Turn Light (Aurora)		P21w
TAIL LIGHTS	Stop/Turn	3157
	Back Up	3156
	Third Brake	921

MISCELLANEOUS

See the brochure for the exterior dimensions, weight ratings, wheel/tire ratings and specifications.

Reporting Safety Defects

If you believe that your vehicle has a defect which could cause a crash or could cause injury or death, you should immediately inform the National Highway Traffic Safety Administration (NHTSA) in addition to notifying Georgie Boy Manufacturing, LLC.

If NHTSA receives similar complaints, it may open an investigation, and if it finds that a safety defect exists in a group of vehicles, it may order a recall and remedy campaign. However, NHTSA cannot become involved in individual problems between you, your dealer, or Georgie Boy RECREATIONAL VEHICLE COMPANY.

To contact NHTSA, you may either call the Auto Safety Hotline toll-free at 1-888-327-4236 or write to:

**National Highway Traffic Safety Administration
400 Seventh St. S.W.
Washington, D.C. 20590**

You can also obtain other information about motor vehicle safety from the Hotline.

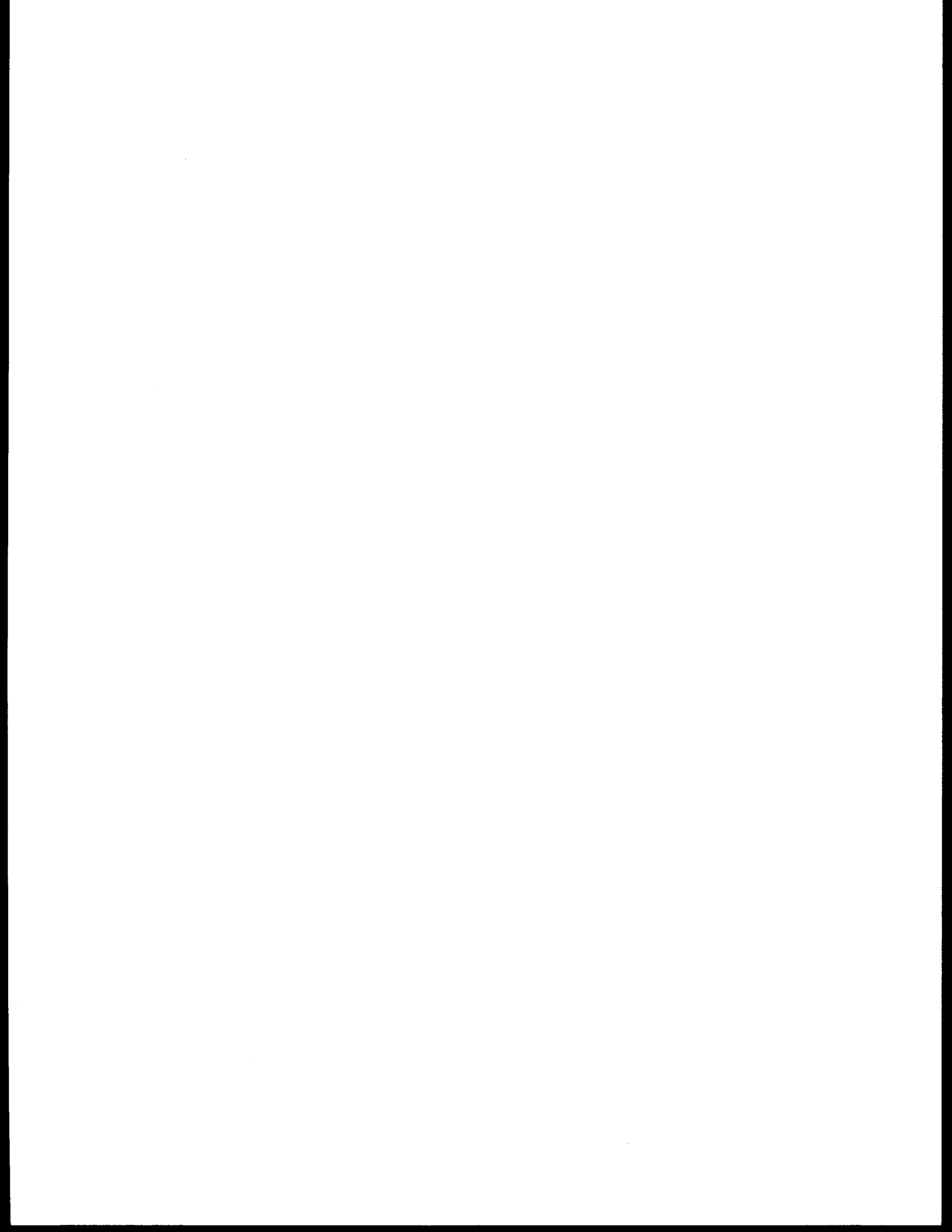



"the motorhome people"®